



MD500-PLUS Series General-Purpose AC Drive Installation Guide



Industrial
Automation



Intelligent
Elevator



New Energy
Vehicle



Industrial
Robot



Rail
Transit



Data code 19011582 A05

Preface

Introduction

The MD500-PLUS series AC drive is a general-purpose high-performance current vector control AC drive designed to control and regulate the speed and torque of three-phase AC asynchronous motors and permanent magnet synchronous motors. It can be used to drive textile machines, paper machines, wire drawing machines, machine tools, packaging machines, food machines, fans, water pumps, and other automated production equipment.

This guide describes the installation and wiring of the AC drive, including installation preparation, unpacking and transportation, mechanical installation, and electrical installation.

More Documents

Document Name	Data Code	Description
MD500-PLUS Series General-Purpose AC Drive Quick Installation and Commissioning Guide	19011581	Describes the installation, wiring, commissioning, troubleshooting, parameters, and fault codes of the AC drive.
MD500-PLUS Series General-Purpose AC Drive Hardware Guide	19011578	Describes the composition, technical specifications, components, dimensions, options (including installation accessories, cables, and peripheral electrical components), and extension cards of the MD500-PLUS series AC drive, as well as routine maintenance and repair, and certifications and standards of the AC drive.
MD500-PLUS Series General-Purpose AC Drive Commissioning Guide	19011579	Describes the software tools, processes, specific steps of the AC drive, as well as troubleshooting, fault codes, and parameters related to the AC drive.
MD500-PLUS Series General-Purpose AC Drive Software Guide	19011580	Describes the function application, communication, fault codes, and parameters of the AC drive.

Revision History

Date	Version	Description
September 2021	A05	Updated the version number on the front and back covers.
November 2020	A04	Corrected minor errors.
July 2020	A00	First release.

Document Acquisition

This guide is not delivered with the AC drive. You can obtain the PDF version of this document using the following method:

Log in to Inovance's website (<http://en.inovance.cn/>), choose **Support > Download**, perform keyword search, and download the PDF file.

Table of Contents

Preface	1
AC Drive Models	6
Fundamental Safety Instructions	8
1 Installation Preparation	14
1.1 Installation Process	14
1.2 Installation Site Inspection	16
1.2.1 Environment	16
1.2.2 Clearances	17
1.2.3 Installation Direction	20
1.3 Installation Tools	21
1.3.1 Tools for Mechanical Installation	21
1.3.2 Wiring Tools	23
1.4 Required Accessories	24
1.4.1 Through-Hole Mounting Bracket	24
1.4.2 Grounding Bracket of Cable Shield	34
1.4.3 Bottom Mounting Bracket	34
1.4.4 Guide Rail	36
2 Dimensions Drawings	37
2.1 T1 to T9 Models	37
2.2 T10 to T12 Models (Without AC Output Reactor)	40
2.3 T10 to T12 Models (with AC Output Reactor)	41
2.4 T13 Models (Without Auxiliary Power Distribution Cabinet)	42
2.5 T13 Models (with Auxiliary Power Distribution Cabinet)	44
3 Unpacking and Transportation	46
3.1 Storage	46
3.2 Transportation Before Unpacking	46
3.3 Packing Verification	50
3.4 Unpacking	57
3.5 Transportation and Lifting After Unpacking	58
4 Mechanical Installation (T1 to T9 Models)	63
4.1 Installation Method	63
4.2 Cabinet Design	63
4.2.1 Overview	63
4.2.2 Cabinet Clearance Requirements	63
4.2.3 Mounting Backplate	64
4.2.4 Cabinet Heat Dissipation Design	65

4.3	Installation Precautions	72
4.4	Backplate Mounting	72
4.5	Through-Hole Mounting	74
4.6	Removing and Installing the Cover	77
4.6.1	Removing the Cover	77
4.6.2	Installing the Cover	80
4.7	Installing the Grounding Bracket of Cable Shield	82
4.8	Installing the Conduit Box	85
5	Mechanical Installation (T10 to T12 Models)	89
5.1	Installation Method	89
5.2	Installation Precautions	89
5.3	Heat Dissipation Design	90
5.4	Installation in a Cabinet	93
5.5	Removing and Installing the Cover	99
5.5.1	Removing the Cover	99
5.5.2	Installing the Cover	100
6	Mechanical Installation (T13 Models)	102
6.1	Installation Method	102
6.2	Installation Precautions	102
6.3	Requirements on Ground Flatness	102
6.4	Installing Expansion Screws	103
6.5	Requirements on Foundation	104
6.6	Installing an External Braking Unit	105
6.7	Checklist of Mechanical Installation	106
7	Electrical Installation	108
7.1	Electrical Wiring Diagram	108
7.2	Inspection Before Wiring	111
7.3	Main Circuit Connection	112
7.3.1	Main Circuit Terminals	112
7.3.2	Main Circuit Terminal Dimensions and Cable Selection	116
7.3.3	Wiring of Main Circuit Terminals	127
7.3.4	Requirements on Wiring of the Main Circuit	129
7.3.5	Protection Requirements	133
7.4	Control Circuit Connection	134
7.4.1	Control Circuit Terminals	134
7.4.2	Wiring of Control Circuit Terminals	136
7.4.3	Requirements on Selection and Routing of Control Circuit Cables	142
7.4.4	Cable Routing Requirements	144

7.4.5	Routing Recommendations	145
7.5	Grounding	150
7.5.1	Grounding Requirements	150
7.5.2	Grounding One AC Drive Alone	151
7.5.3	Grounding Multiple AC Drives Installed Side by Side	152
7.5.4	Grounding the Cabinet System	153
7.6	Communication Connection	154
7.6.1	RS485 Wiring	154
7.6.2	CAN Communication Wiring	156
7.6.3	EtherCAT Wiring	158
7.6.4	PROFINET Wiring	159
7.7	Inspection After Wiring	160
8	Installation of Options	161
8.1	AC Input Reactor	161
8.2	Output Reactor	161
8.3	Fuses, Contactors, and Circuit Breakers	161
8.4	EMC Filter	161
8.5	Simple Filter	162
8.6	Magnetic Ring and Ferrite Clamp	163
9	Troubleshooting for Common EMC Interference Problems	166
9.1	Leakage Current Suppression	166
9.2	Earth leakage Circuit Breaker Malfunction	166
9.3	Harmonic Suppression	168
9.4	Control Circuit Interference	169
9.4.1	High-Speed Pulse Interference	169
9.4.2	Common I/O Signal Interference	169
9.5	Communication Interference	170
9.5.1	RS485 and CAN Communication Interference	170
9.5.2	EtherCAT and PROFINET Communication Interference	170
9.6	Encoder Feedback Signal Errors	171

AC Drive Models

The following table lists the relationship between the AC drive model and structure.

Table –1 Relationship between the AC drive model and structure

Structure	AC Drive Model (Three-phase 380 V to 480 V)	AC Drive Model (Three-phase 200 V to 240 V)	AC Drive Model (Single- phase 200 V to 240 V)
T1	MD500T0.4G/0.7PB-PLUS MD500T0.7G/1.1PB-PLUS MD500T1.1G/1.5PB-PLUS MD500T1.5G/2.2PB-PLUS MD500T2.2G/3.0PB-PLUS MD500T3.0G/3.7PB-PLUS	MD500-2T0.4G/0.7PB-PLUS MD500-2T0.7G/1.1PB-PLUS MD500-2T1.1G/1.5PB-PLUS MD500-2T1.5G/2.2PB-PLUS	-
T2	MD500T3.7G/5.5PB-PLUS MD500T5.5G/7.5PB-PLUS	MD500-2T2.2G/3.7PB-PLUS MD500-2T3.7G/5.5PB-PLUS	MD500-2S0.4GB-PLUS MD500-2S0.7GB-PLUS MD500-2S1.5GB-PLUS MD500-2S2.2GB-PLUS
T3	MD500T7.5G/11PB-PLUS MD500T11G/15PB-PLUS	MD500-2T5.5G/7.5PB-PLUS	-
T4	MD500T15G/18.5PB-PLUS	MD500-2T7.5G/11PB-PLUS	-
T5 (without DC reactor)	MD500T18.5G/22P(B)-PLUS MD500T22G/30P(B)-PLUS	MD500-2T11G/15P(B)-PLUS	-
T5 (with DC reactor)	MD500T18.5G/22P(B)-T-PLUS MD500T22G/30P(B)-T-PLUS	-	-
T6	MD500T30G/37P(B)-PLUS MD500T37G/45P(B)-PLUS	MD500-2T15G/18.5P(B)-PLUS MD500-2T18.5G/22P(B)-PLUS	-
T7	MD500T45G/55P(B)-PLUS MD500T55G/75P(B)-PLUS	MD500-2T22G/30P(B)-PLUS MD500-2T30G/37P(B)-PLUS	-
T8	MD500T75G/90P(B)-PLUS MD500T90G/110P-PLUS MD500T110G/132P-PLUS	MD500-2T37G/45P(B)-PLUS MD500-2T45G/55P-PLUS MD500-2T55G/75P-PLUS	-
T9	MD500T132G/160P-PLUS MD500T160G/200P-PLUS	MD500-2T75G/90P-PLUS	-
T10 (without AC output reactor)	MD500T200G/250P-PLUS MD500T220G/280P-PLUS	MD500-2T90G/110P-PLUS MD500-2T110G/132P-PLUS	-
T10 (with AC output reactor)	MD500T200G/250P-L-PLUS MD500T220G/280P-L-PLUS	-	-
T11 (without AC output reactor)	MD500T250G/315P-PLUS MD500T280G/355P-PLUS	MD500-2T132G/160P-PLUS	-
T11 (with AC output reactor)	MD500T250G/315P-L-PLUS MD500T280G/355P-L-PLUS	-	-
T12 (without AC output reactor)	MD500T315G/400P-PLUS MD500T355G/450P-PLUS MD500T400G/500P-PLUS	MD500-2T160G/200P-PLUS MD500-2T200G/220P-PLUS	-
T12 (with AC output reactor)	MD500T315G/400P-L-PLUS MD500T355G/450P-L-PLUS MD500T400G/500P-L-PLUS	-	-

Structure	AC Drive Model (Three-phase 380 V to 480 V)	AC Drive Model (Three-phase 200 V to 240 V)	AC Drive Model (Single- phase 200 V to 240 V)
T13 (without auxiliary power distribution cabinet)	MD500T500G/630P-PLUS MD500T560G/710P-PLUS MD500T630G/800P-PLUS	-	-
T13 (with auxiliary power distribution cabinet)	MD500T500G/630P-A-PLUS MD500T560G/710P-A-PLUS MD500T630G/800P-A-PLUS	-	-

Fundamental Safety Instructions

Safety Precautions

1. This chapter presents essential safety instructions for a proper use of the equipment. Before operating the equipment, read through the guide and comprehend all the safety instructions. Failure to comply with the safety instructions may result in death, severe personal injuries, or equipment damage.
2. "CAUTION", "WARNING", and "DANGER" items in the guide only indicate some of the precautions that need to be followed; they just supplement the safety precautions.
3. Use this equipment according to the designated environment requirements. Damage caused by improper use is not covered by warranty.
4. Inovance shall take no responsibility for any personal injuries or property damage caused by improper use.

Safety Levels and Definitions



Indicates that failure to comply with the notice will result in death or severe personal injuries.



Indicates that failure to comply with the notice may result in death or severe personal injuries.



Indicates that failure to comply with the notice may result in minor or moderate personal injuries or equipment damage.

General Safety Instructions

- Drawings in the guide are sometimes shown without covers or protective guards. Remember to install the covers or protective guards as specified first, and then perform operations in accordance with the instructions.
- The drawings in the guide are shown for illustration only and may be different from the product you purchased.

Unpacking



- Do not install the equipment if you find damage, rust, or signs of use on the equipment or accessories upon unpacking.
- Do not install the equipment if you find water seepage or missing or damaged components upon unpacking.
- Do not install the equipment if you find the packing list does not conform to the equipment you received.

 CAUTION

- Check whether the packing is intact and whether there is damage, water seepage, dampness, and deformation before unpacking.
- Unpack the package by following the unpacking sequence. Do not strike the package violently.
- Check whether there is damage, rust, or injuries on the surface of the equipment and equipment accessories before unpacking.
- Check whether the package contents are consistent with the packing list before unpacking.

Storage and Transportation WARNING

- Large-scale or heavy equipment must be transported by qualified professionals using specialized hoisting equipment. Failure to comply may result in personal injuries or equipment damage.
- Before hoisting the equipment, ensure the equipment components such as the front cover and terminal blocks are secured firmly with screws. Loosely-connected components may fall off and result in personal injuries or equipment damage.
- Never stand or stay below the equipment when the equipment is being hoisted by the hoisting equipment.
- When hoisting the equipment with a steel rope, ensure the equipment is hoisted at a constant speed without suffering from vibration or shock. Do not turn the equipment over or let the equipment stay hanging in the air. Failure to comply may result in personal injuries or equipment damage.

 CAUTION

- Handle the equipment with care during transportation and mind your steps to prevent personal injuries or equipment damage.
- When carrying the equipment with bare hands, hold the equipment casing firmly with care to prevent parts from falling. Failure to comply may result in personal injuries.
- Store and transport the equipment based on the storage and transportation requirements. Failure to comply will result in equipment damage.
- Avoid storing or transporting the equipment in environments with water splash, rain, direct sunlight, strong electric field, strong magnetic field, and strong vibration.
- Avoid storing the equipment for more than three months. Long-term storage requires stricter protection and necessary inspections.
- Pack the equipment strictly before transportation. Use a sealed box for long-distance transportation.
- Never transport the equipment with other equipment or materials that may harm or have negative impacts on this equipment.

Installation DANGER

- The equipment must be operated only by professionals with electrical knowledge.

 WARNING

- Read through the guide and safety instructions before installation.
- Do not install this equipment in places with strong electric or magnetic fields.
- Before installation, check that the mechanical strength of the installation site can bear the weight of the equipment. Failure to comply will result in mechanical hazards.
- Do not wear loose clothes or accessories during installation. Failure to comply may result in an electric shock.
- When installing the equipment in a closed environment (such as a cabinet or casing), use a cooling device (such as a fan or air conditioner) to cool the environment down to the required temperature. Failure to comply may result in equipment over-temperature or a fire.
- Do not retrofit the equipment.
- Do not fiddle with the bolts used to fix equipment components or the bolts marked in red.
- When the equipment is installed in a cabinet or final assembly, a fireproof enclosure providing both electrical and mechanical protections must be provided. The IP rating must meet IEC standards and local laws and regulations.
- Before installing devices with strong electromagnetic interference, such as a transformer, install a shielding device for the equipment to prevent malfunction.
- Install the equipment onto an incombustible object such as a metal. Keep the equipment away from combustible objects. Failure to comply will result in a fire.

 CAUTION

- Cover the top of the equipment with a piece of cloth or paper during installation. This is to prevent unwanted objects such as metal shavings, oil, and water from falling into the equipment and causing faults. After installation, remove the cloth or paper on the top of the equipment to prevent over-temperature caused by poor ventilation due to blocked ventilation holes.
- Resonance may occur when the equipment operating at a constant speed executes variable speed operations. In this case, install the vibration-proof rubber under the motor frame or use the vibration suppression function to reduce resonance.

Wiring

 DANGER

- Equipment installation, wiring, maintenance, inspection, or parts replacement must be performed only by professionals.
- Before wiring, cut off all the power supplies of the equipment, and wait for at least the time designated on the equipment warning label before further operations because residual voltage still exists after power-off. After waiting for the designated time, measure the DC voltage in the main circuit to ensure the DC voltage is within the safe voltage range. Failure to comply will result in an electric shock.
- Do not perform wiring, remove the equipment cover, or touch the circuit board with power ON. Failure to comply will result in an electric shock.
- Check that the equipment is grounded properly. Failure to comply will result in an electric shock.

 WARNING

- Do not connect the input power supply to the output end of the equipment. Failure to comply will result in equipment damage or even a fire.
- When connecting a drive to the motor, check that the phase sequences of the drive and motor terminals are consistent to prevent reverse motor rotation.
- Cables used for wiring must meet cross sectional area and shielding requirements. The shield of the cable must be reliably grounded at one end.
- Fix the terminal screws with the tightening torque specified in the user guide. Improper tightening torque may overheat or damage the connecting part, resulting in a fire.
- After wiring is done, check that all cables are connected properly and no screws, washers or exposed cables are left inside the equipment. Failure to comply may result in an electric shock or equipment damage.

 CAUTION

- During wiring, follow the proper electrostatic discharge (ESD) procedure, and wear an antistatic wrist strap. Failure to comply will damage the equipment or the internal circuits of the equipment.
- Use shielded twisted pairs for the control circuit. Connect the shield to the grounding terminal of the equipment for grounding purpose. Failure to comply will result in equipment malfunction.

Power-on

 DANGER

- Before power-on, check that the equipment is installed properly with reliable wiring and the motor can be restarted.
- Check that the power supply meets equipment requirements before power-on to prevent equipment damage or a fire.
- After power-on, do not open the cabinet door or protective cover of the equipment, touch any terminal, or disassemble any unit or component of the equipment. Failure to comply will result in an electric shock.





 WARNING

- Perform a trial run after wiring and parameter setting to ensure the equipment operates safely. Failure to comply may result in personal injuries or equipment damage.
- Before power-on, check that the rated voltage of the equipment is consistent with that of the power supply. Failure to comply may result in a fire.
- Before power-on, check that no one is near the equipment, motor, or machine. Failure to comply may result in death or personal injuries.

Operation

 DANGER



- The equipment must be operated only by professionals. Failure to comply will result in death or personal injuries.
- Do not touch any connecting terminals or disassemble any unit or component of the equipment during operation. Failure to comply will result in an electric shock.

 WARNING <ul style="list-style-type: none">• Do not touch the equipment casing, fan, or resistor with bare hands to feel the temperature. Failure to comply may result in personal injuries.• Prevent metal or other objects from falling into the equipment during operation. Failure to comply may result in a fire or equipment damage.
Maintenance
 DANGER <ul style="list-style-type: none">• Equipment installation, wiring, maintenance, inspection, or parts replacement must be performed only by professionals.• Do not maintain the equipment with power ON. Failure to comply will result in an electric shock.• Before maintenance, cut off all the power supplies of the equipment and wait for at least the time designated on the equipment warning label.• In case of a permanent magnet motor, do not touch the motor terminals immediately after power-off because the motor terminals will generate induced voltage during rotation even after the equipment power supply is off. Failure to comply will result in an electric shock.
 WARNING <ul style="list-style-type: none">• Perform routine and periodic inspection and maintenance on the equipment according to maintenance requirements and keep a maintenance record.
Repair
 DANGER <ul style="list-style-type: none">• Equipment installation, wiring, maintenance, inspection, or parts replacement must be performed only by professionals.• Do not repair the equipment with power ON. Failure to comply will result in an electric shock.• Before inspection and repair, cut off all the power supplies of the equipment and wait for at least the time designated on the equipment warning label.
 WARNING <ul style="list-style-type: none">• When the fuse is blown or the circuit breaker or earth leakage current breaker (ELCB) trips, wait for at least the time designated on the equipment warning label before power-on or further operations. Failure to comply may result in death, personal injuries or equipment damage.• When the equipment is faulty or damaged, the troubleshooting and repair work must be performed by professionals that follow the repair instructions, with repair records kept properly.• Replace quick-wear parts of the equipment according to the replacement instructions.• Do not use damaged equipment. Failure to comply may result in death, personal injuries, or severe equipment damage.• After the equipment is replaced, check the wiring and set parameters again.

Disposal
<div style="border: 1px solid black; padding: 5px; margin-bottom: 10px;">  WARNING </div> <ul style="list-style-type: none"> • Dispose of retired equipment in accordance with local regulations and standards. Failure to comply may result in property damage, personal injuries, or even death. • Recycle retired equipment by observing industry waste disposal standards to avoid environmental pollution.

Safety Labels

For safe equipment operation and maintenance, comply with the safety labels on the equipment. Do not damage or remove the safety labels. See the following table for descriptions of the safety labels.

Safety Signs		Description
T1 to T12 models		<ul style="list-style-type: none"> • Read through the safety instructions before operating the equipment. Failure to comply may result in equipment damage, personal injuries, or even death. • Do not touch terminals or remove the cover while the power is on or within 10 minutes after the power is turned off. Failure to comply may result in an electric shock.
T13 models		<ul style="list-style-type: none"> • Read through the safety instructions before operating the equipment. Failure to comply may result in equipment damage, personal injuries, or even death. • Do not touch terminals or remove the cover while the power is on or within 15 minutes after the power is turned off. Failure to comply may result in an electric shock.

1 Installation Preparation

1.1 Installation Process

T1 to T9 models

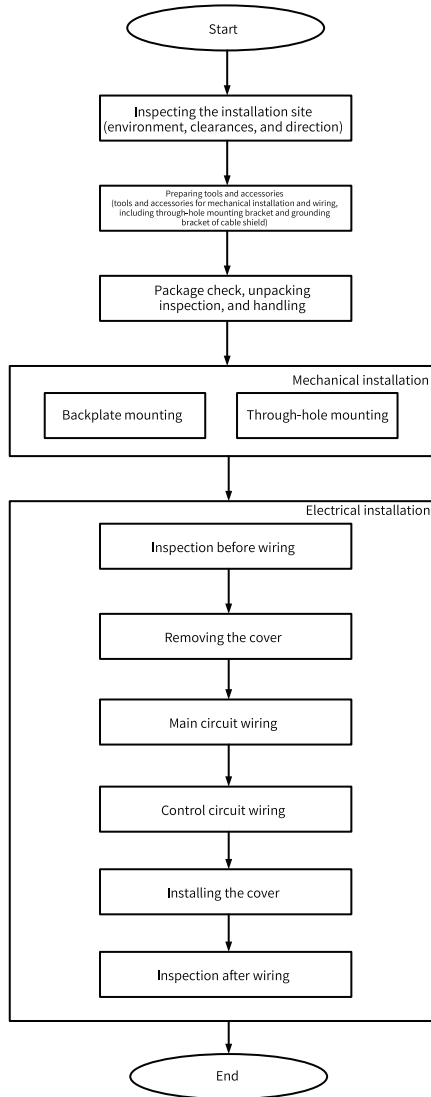

Figure 1-1 General installation process (T1 to T9 models)

T10 to T12 models

Figure 1-2 General installation process (T10 to T12 models)

T13 models

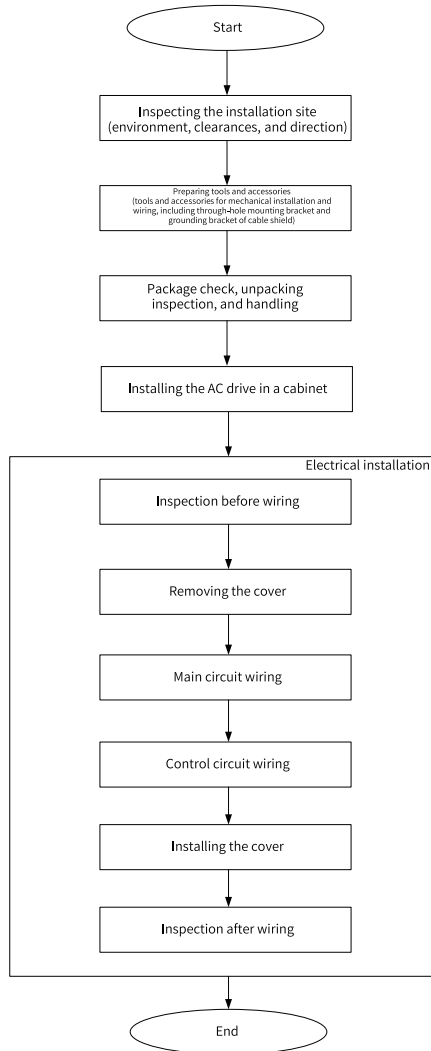
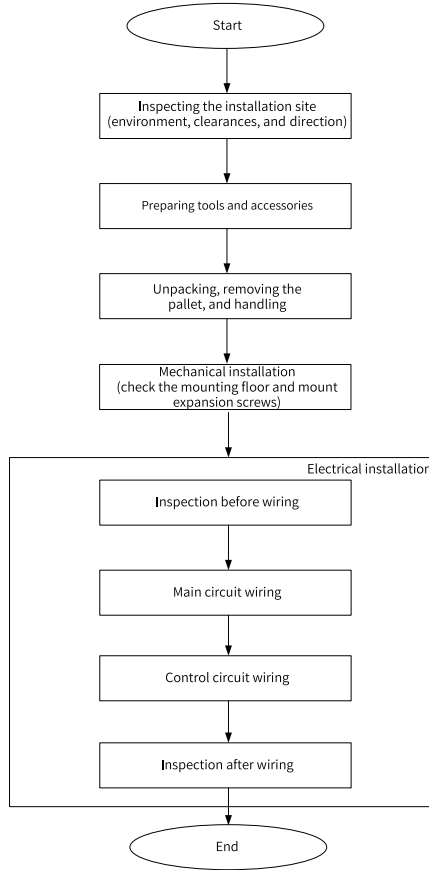

Figure 1-3 General installation process (T13 models)

1.2 Installation Site Inspection

1.2.1 Environment

To give its performance full play and ensure a long service life, install the AC drive in an environment specified as follows.

Table 1-1 Environment requirements

Item	Requirement
Installation Location	Indoor
Grid overvoltage	Overvoltage category (OVC) III

Item	Requirement
Temperature	Installation/Running temperature: -10°C to $+50^{\circ}\text{C}$ (No derating is required when the temperature ranges from -10°C to $+40^{\circ}\text{C}$. For temperature above 40°C , derate 1.5% for every additional 1°C .) Storage/Transportation temperature: -20°C to $+60^{\circ}\text{C}$ <ul style="list-style-type: none"> • For better reliability, use the AC drive in places without sharp temperature changes. • For use in an enclosed space such as a control cabinet, use a cooling fan or air conditioner to keep the temperature of air taken into the AC drive below 50°C. Failure to comply may result in over-temperature or fire. • Install the AC drive on a flame retardant object, with sufficient clearance reserved for heat dissipation. • Avoid freezing of the AC drive.
Humidity	< 95% RH, without condensation
Environment	Pollution degree 2 or below Install the AC drive in a place that meets the following requirements: <ul style="list-style-type: none"> • free of direct sunlight, dust, corrosive gas, combustible or explosive gas, oil mist, water vapor, drip, or salt. • away from sources that may generate vibration, especially away from equipment such as punch presses. • away from unwanted objects such as metal powder, oil, and water. • free of radioactive materials, combustible materials, and hazardous gas and liquid, with little salt corrosion. Install the AC drive on an incombustible surface.
Altitude	<ul style="list-style-type: none"> • No derating is required for altitudes below 1000 m. • For altitudes above 1000 m, derate 1% for every additional 100 m. 0.4–3 kW: The maximum altitude is 2000 m. For altitudes above 2000 m, contact Inovance. Above 3 kW: The maximum altitude is 3000 m. For altitudes above 3000 m, contact Inovance.
Vibration resistance	<ul style="list-style-type: none"> • For transportation with package: compliant with Class 2M3 requirements in EN 60721-3-2 • For installation with package removed: compliant with ISTA 1H

1.2.2 Clearances

Reserve sufficient clearances as appropriate to the power rating of the AC drive.

T1 to T9 models

- Installing an individual AC drive

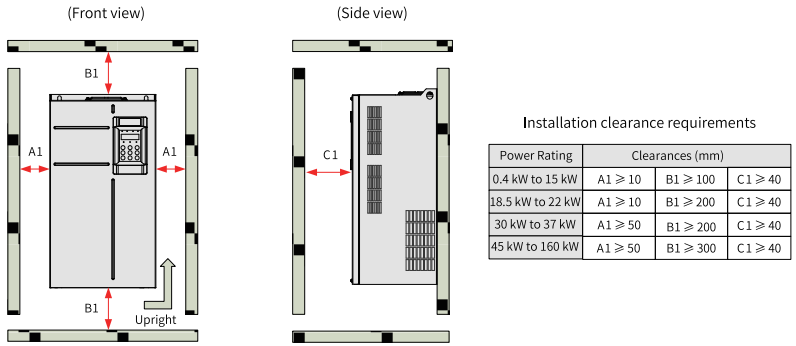

Figure 1-4 Space for installation of one AC drive (T1 to T9 models)

- Installing multiple AC drives side by side

The AC drive dissipates heat upward. When multiple AC drives are required to work together, install them side by side. Keep their tops level with each other, especially for those of different sizes.

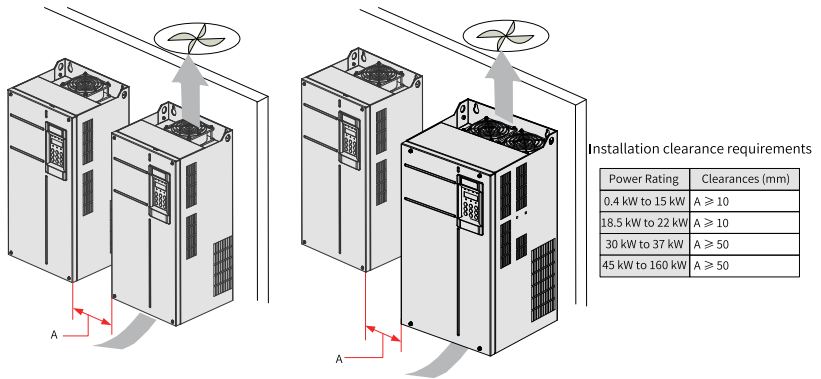

Figure 1-5 Installing multiple AC drives (T1 to T9 models) side by side

- Installing one AC drive above another

Where up and down arrangement is necessary, the heat generated by the AC drive below overheat the one above, leading to overtemperature/overload fault. Therefore, an air guide plate must be installed, as shown in ["Figure 1-6 Installing one AC drive above another" on page 19.](#)

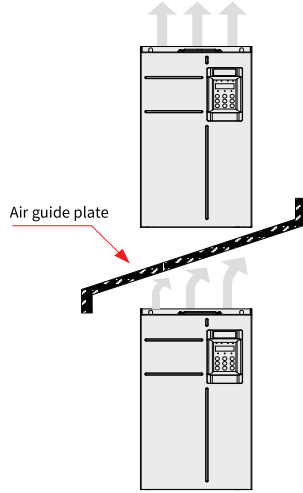

Figure 1-6 Installing one AC drive above another

T10 to T12 models

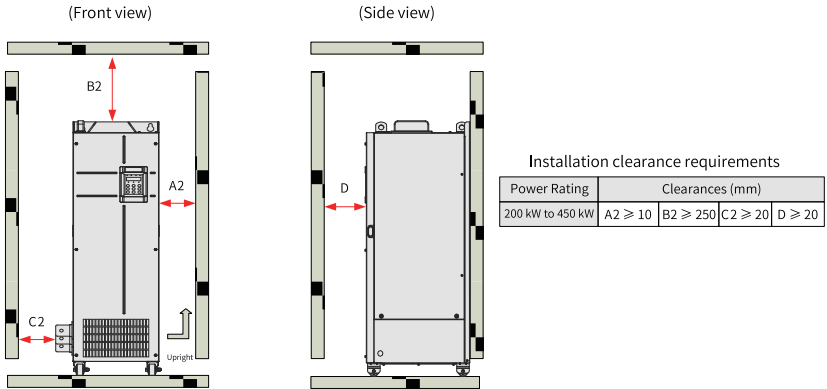

Figure 1-7 Space for installation of T10 to T12 models

Note

T10 to T12 models can only be installed individually inside the cabinet. For installation needs, contact Invoance.

T13 models

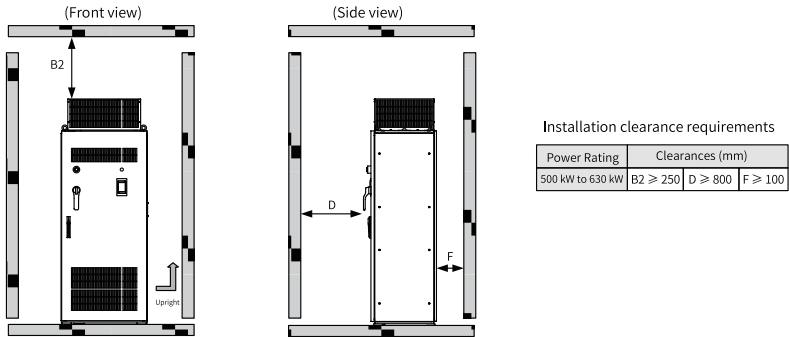

Figure 1-8 Space for installation of T10 to T12 models

1.2.3 Installation Direction

Install the AC drive upright only, as shown in ["Figure 1-10" on page 21](#).

Avoid stress on any side of the AC drive or place it on an inclined surface. The AC drive is large and heavy (close to 200 kg). If the inclination exceeds 5°, it may topple.

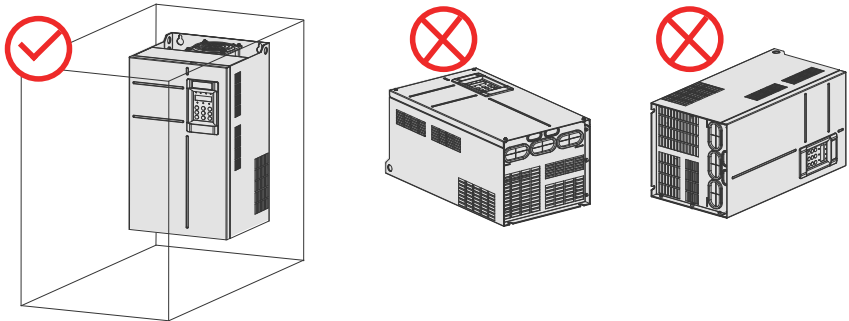

Figure 1-9 Installation direction (T1 to T9 models)

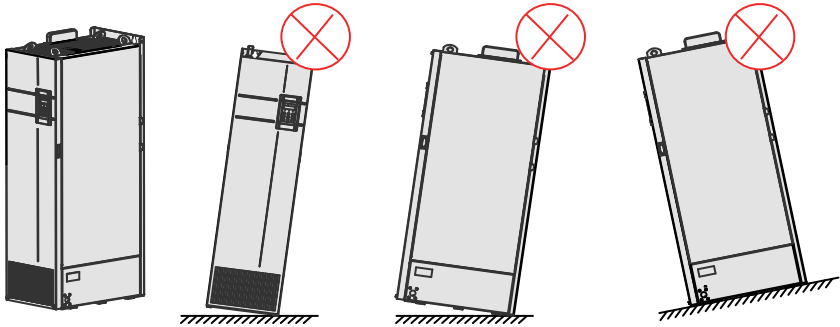

Figure 1-10 Installation direction (T10 to T12 models)

1.3 Installation Tools

1.3.1 Tools for Mechanical Installation

T1 to T9 models

"[Table 1-2 Tools for mechanical installation](#)" on [page 21](#) lists the tools for mechanical installation.

Table 1-2 Tools for mechanical installation

Tool	Description
Electric drill with an appropriate drilling bit	Used to drill mounting holes into the mounting surface.
Wrench or socket wrench	Used to tighten or loosen screws. Wrench sizes include 13 mm, 16 mm, and 18 mm.
Phillips and slotted (2.5–6 mm) screwdrivers	Used to tighten or loosen screws.
Torque wrench	Used to tighten or loosen screws.
Crowbar	Used to pry off the upper access cover or cover to facilitate installation.
Crane	Used to lift the equipment.
Tape measure	Used to measure the installation dimensions of the equipment.
Gloves	Used to prevent static electricity.
Bottom mounting bracket (standard)	When the AC drive is installed in a cabinet, a bottom mounting bracket is used to fix it in the cabinet.

Tool	Description
Guide rails (optional)	When the AC drive is installed in a cabinet, the guide rails are connected to the bottom mounting bracket, allowing the AC drive to be gently pushed into the cabinet along the guide rails.
Screws	Used to fix the equipment onto the mounting surface.

"Table 1-3 Specifications and quantities of screws" on page 22 lists the specifications and quantities of screws required for mechanical installation.

Table 1-3 Specifications and quantities of screws

Installation Method	Specification	Quantity (Pieces)	Description
Backplate Mounting	Dependent on the mounting hole diameter (purchased by the user).	4	Used to fix the equipment onto the wall.
Through-hole mounting	Dependent on the mounting hole diameter (purchased by the user).	4	Used to fix the AC drive onto the backplate of the control cabinet.

T10 to T12 models

"Table 1-2 Tools for mechanical installation" on page 21 lists the tools for mechanical installation.

"Table 1-4 Specifications and quantities of screws" on page 22 lists the specifications and quantities of screws required for mechanical installation.

Table 1-4 Specifications and quantities of screws

Installation Method	Specification	Quantity (Pieces)	Description
Installation in a cabinet	M5 self-tapping screw	6	Used to fix the bottom mounting bracket to the bottom of the cabinet.
	M5 x 12 SEMS screw	8	Used to make the guide rail assembly.
	M6 nut	2	Used to connect the guide rail assembly to the bottom mounting bracket.

T13 models

"[Table 1-5 Tools for mechanical installation](#)" on [page 23](#) lists the tools for mechanical installation.

Table 1-5 Tools for mechanical installation

Tool	Description
Wrench or socket wrench (18 mm)	Used to tighten or loosen screws.
Phillips and slotted (2.5–6 mm) screwdrivers	Used to tighten or loosen screws.
Torque wrench (torque above 100 N•m)	Used to tighten or loosen screws.
Electric drill with an appropriate drilling bit	Used to drill holes into the floor or steel plates for fastening the cabinet.
Crowbar	Used to pry off the upper access cover or cover to facilitate installation.
Crane	Used to lift the equipment.
Tape measure	Used to measure the installation dimensions of the equipment.
Gloves	Used to prevent static electricity.

1.3.2 Wiring Tools

For wiring of main circuit terminals, consider the terminal dimensions and use appropriate installation tools to secure the joints. For details about the required tools for wiring of the main circuit terminals, see "[Table 1-6 Tools for wiring of main circuit terminals](#)" on [page 23](#).

Table 1-6 Tools for wiring of main circuit terminals

Model	Recommended Fastener	Tools
T1 to T2	M4 SEMS screw	Phillips screwdriver (#3)
T3 to T4	M5 SEMS screw	Phillips screwdriver (#3)
T5 to T6	M6 SEMS screw	Phillips screwdriver (#3)
T7	M8 nut, spring washer, and flat washer	Socket wrench (13 mm)
T8 to T9	M12 nut, spring washer, and flat washer	Socket wrench (19 mm) and socket wrench extension bar (150 mm)
T10 to T11	M12 bolt, spring washer, and flat washer	Socket wrench (19 mm) and socket wrench extension bar (250 mm)

Model	Recommended Fastener	Tools
T12	M16 bolt, spring washer, and flat washer	Socket wrench (24 mm) and socket wrench extension bar (250 mm)
T13	M12 bolt, spring washer, and flat washer	Socket wrench (24 mm) and socket wrench extension bar (250 mm)

1.4 Required Accessories

1.4.1 Through-Hole Mounting Bracket

The through-hole mounting bracket is optional and can be purchased as needed.

Applicable models

Table 1-7 Models of through-hole mounting brackets

Models of Through-hole Mounting Brackets	Structure
MD500-AZJ-A1T1	T1
MD500-AZJ-A1T2	T2
MD500-AZJ-A1T3	T3
MD500-AZJ-A1T4	T4
MD500-AZJ-A1T5	T5
MD500-AZJ-A1T6	T6
MD500-AZJ-A1T7	T7
MD500-AZJ-A1T8	T8
MD500-AZJ-A1T9	T9

Mounting hole dimensions

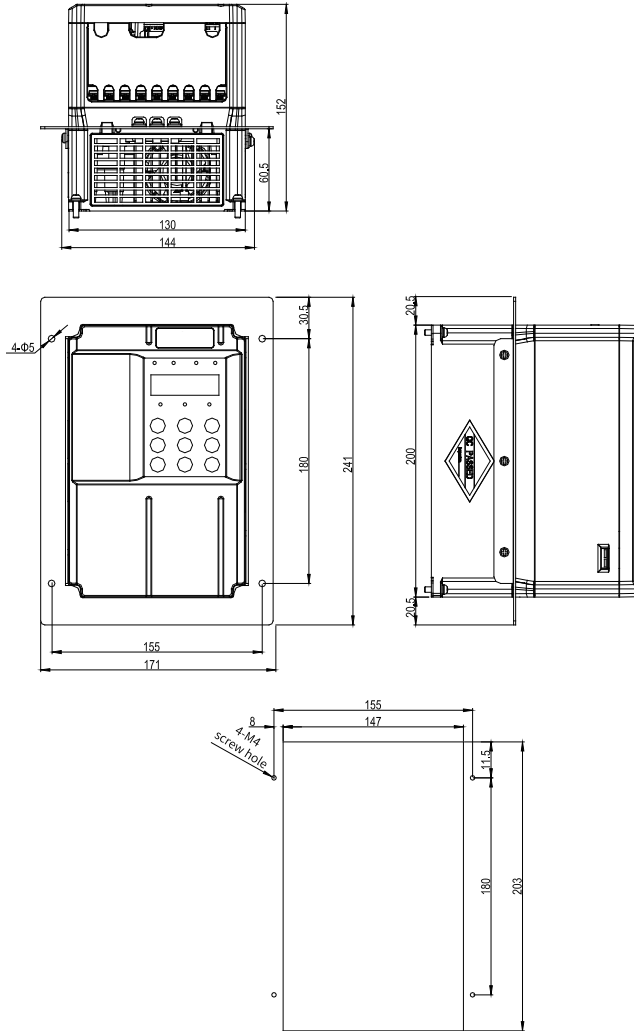

Figure 1-11 Dimensions of MD500-AZJ-A1T1 through-hole mounting bracket and mounting holes

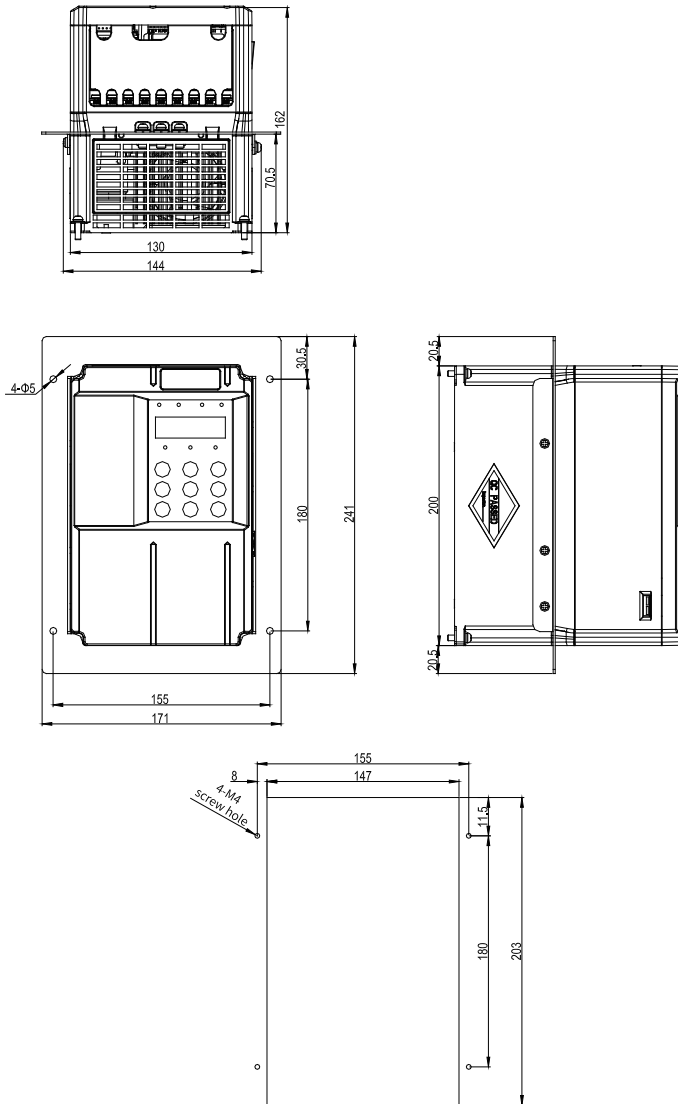

Figure 1-12 Dimensions of MD500-AZJ-A1T2 through-hole mounting bracket and mounting holes

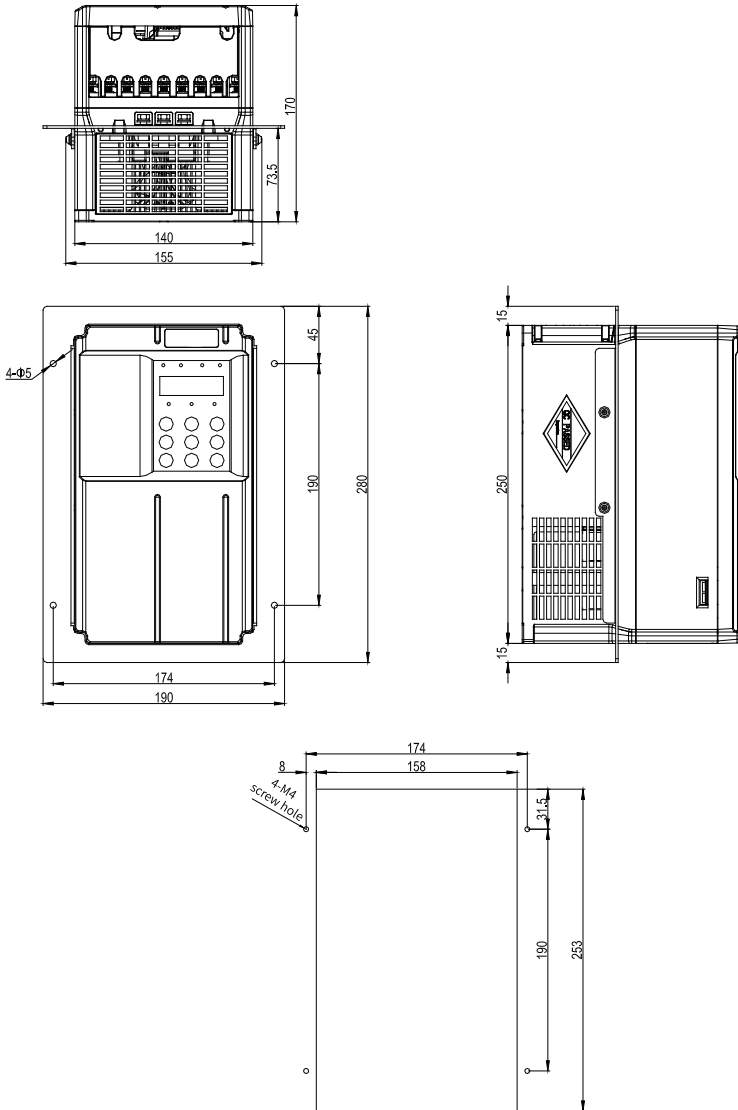

Figure 1-13 Dimensions of MD500-AZJ-A1T3 through-hole mounting bracket and mounting holes

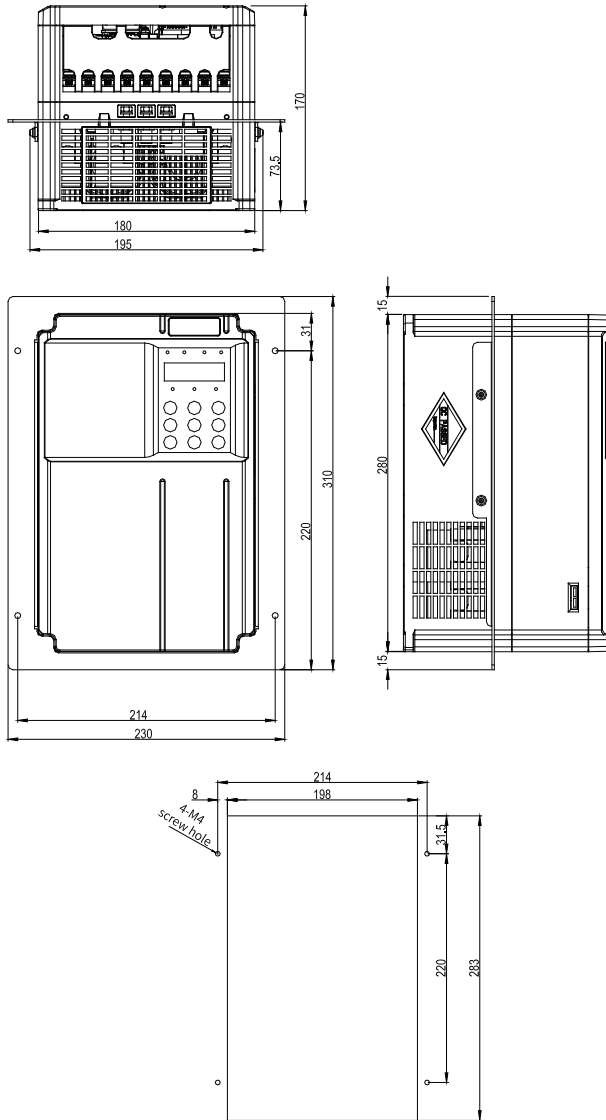

Figure 1-14 Dimensions of MD500-AZJ-A1T4 through-hole mounting bracket and mounting holes

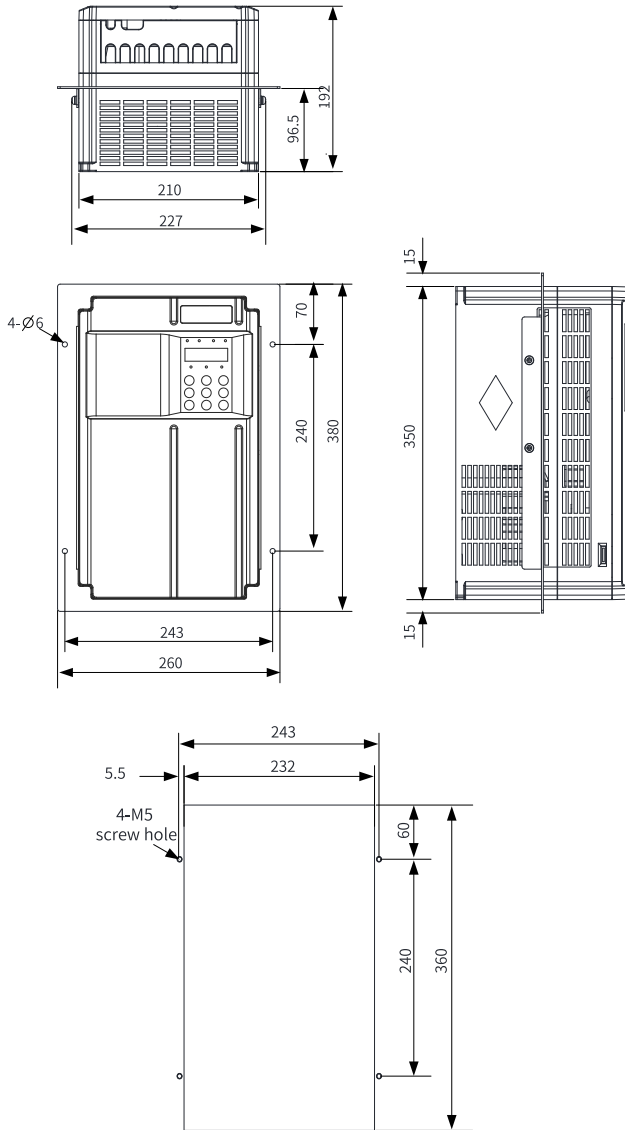

Figure 1-15 Dimensions of MD500-AZJ-A1T5 through-hole mounting bracket and mounting holes

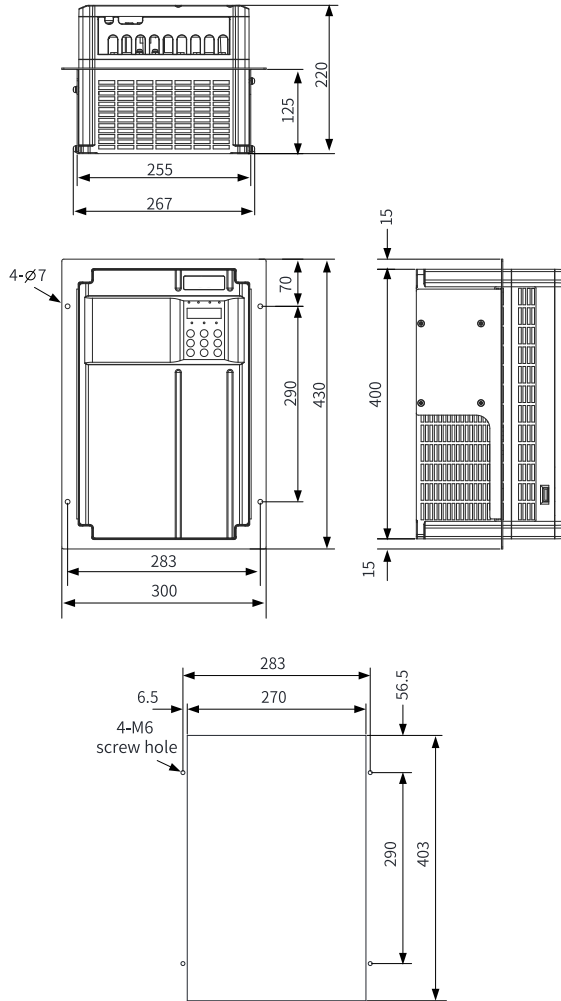

Figure 1-16 Dimensions of MD500-AZJ-A1T6 through-hole mounting bracket and mounting holes

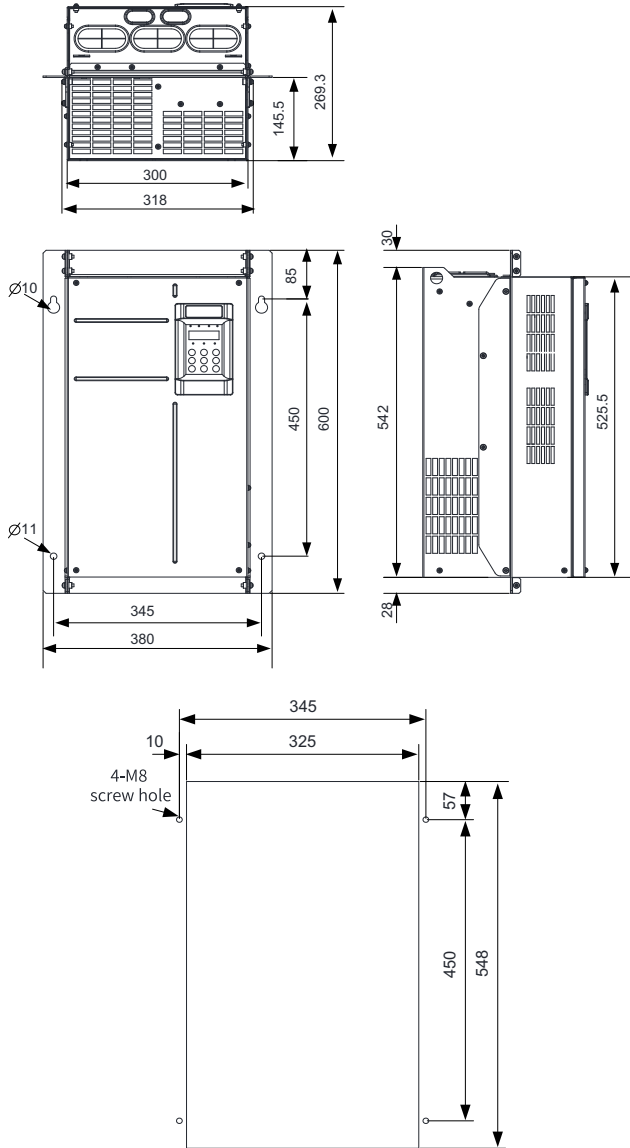

Figure 1-17 Dimensions of MD500-AZJ-A1T7 through-hole mounting bracket and mounting holes

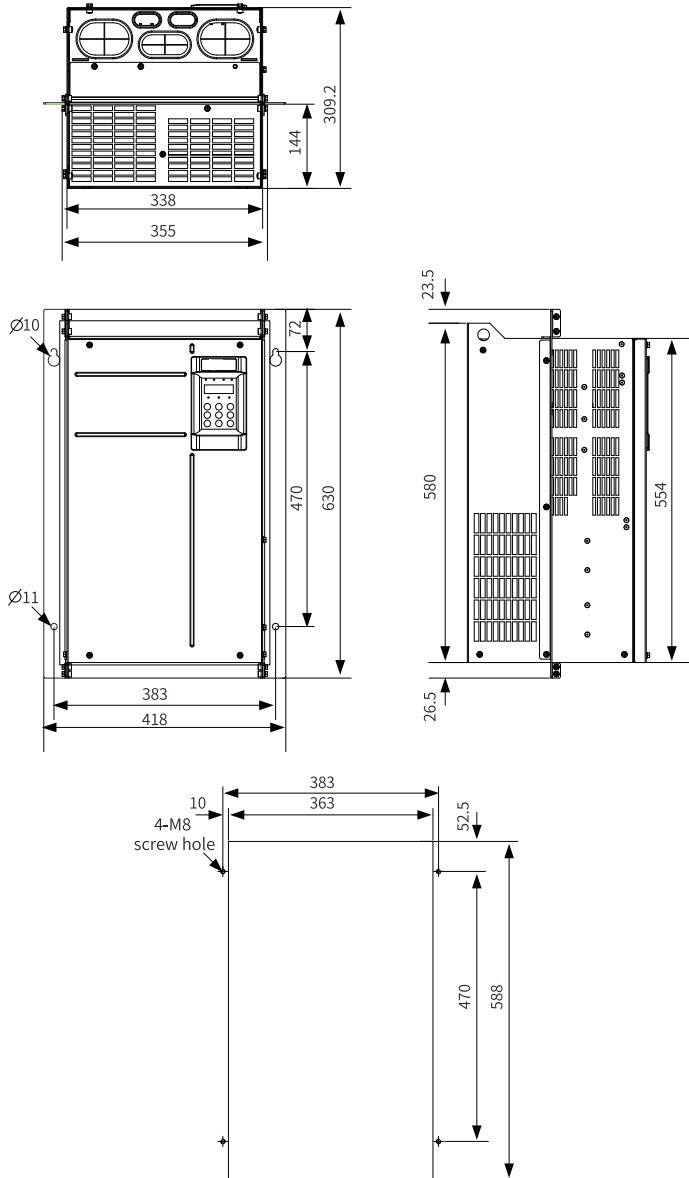

Figure 1-18 Dimensions of MD500-AZJ-A1T8 through-hole mounting bracket and mounting holes

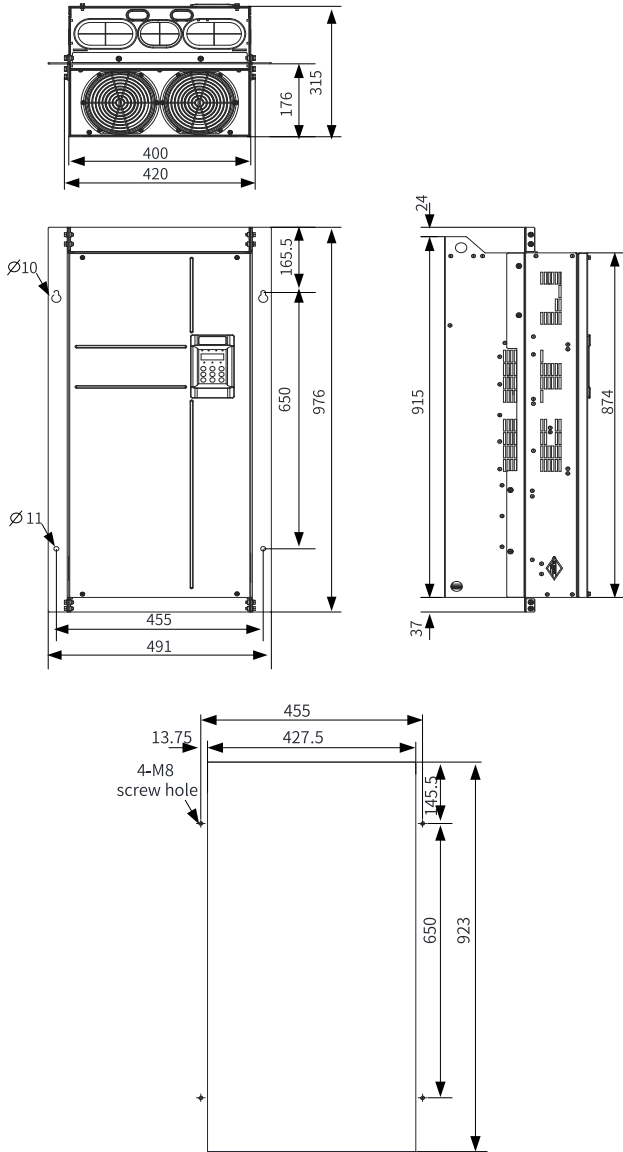

Figure 1-19 Dimensions of MD50-AZJ-A1T9 through-hole mounting bracket and mounting holes

1.4.2 Grounding Bracket of Cable Shield

The grounding bracket of cable shield is optional and can be purchased separately as required (applicable to T9 models and below).

1.4.3 Bottom Mounting Bracket

The bottom mounting bracket is standard for T10 to T12 models. When the AC drive is installed in a cabinet, a bottom mounting bracket is required for fixing the AC drive to the cabinet rack base. The dimensions of bottom mounting bracket depend on the power rating, weight, and size of the AC drive, as shown in the following figures.

A 600 mm cabinet is delivered with the AC drive. If you need an 800 mm cabinet, contact Inovance.

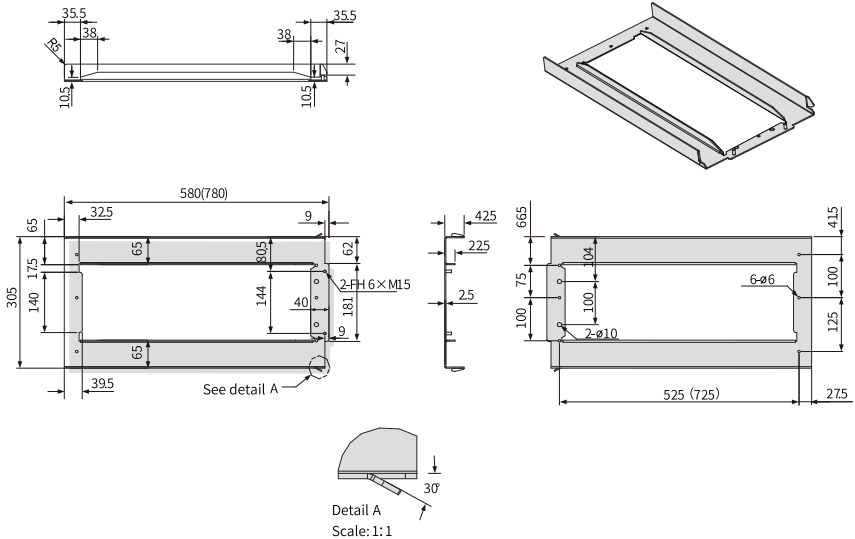

Figure 1-20 Dimensions of bottom mounting bracket for T10 models (mm)

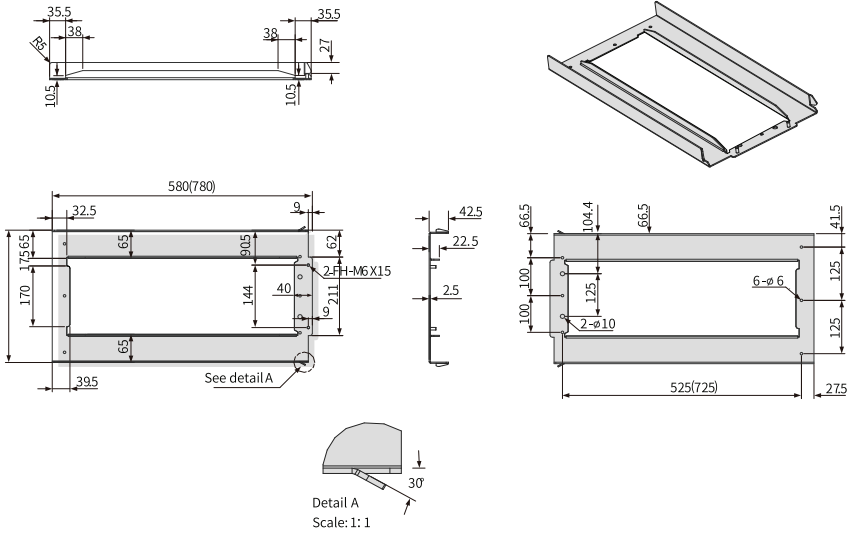

Figure 1-21 Dimensions of bottom mounting bracket for T11 models (mm)

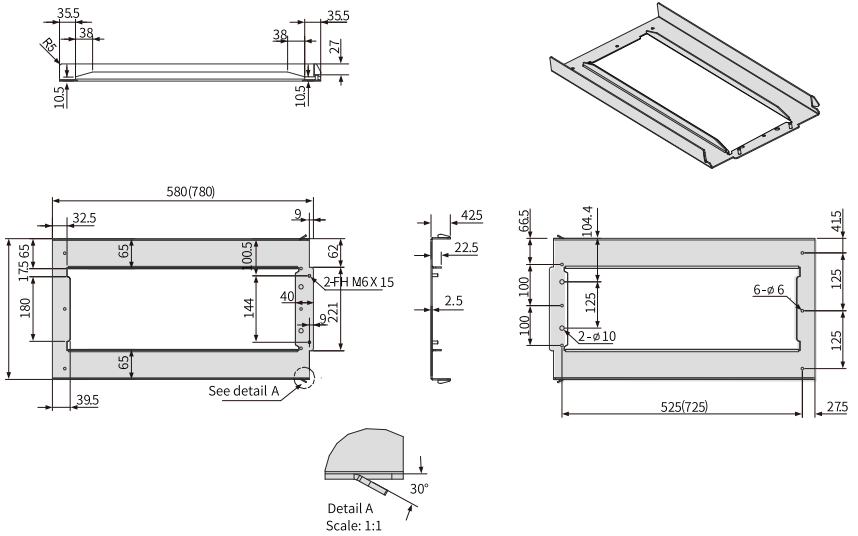

Figure 1-22 Dimensions of bottom mounting bracket for T12 models (mm)

Note

- The rail diagram applies to PS cabinets (800 x 600 or 800 x 800 (W x D) in mm).
 - Dimensions inside the parentheses apply to standard PS cabinets with a depth of 800 mm.
-

1.4.4 Guide Rail

For details of the guide rail, see *Operation Instructions for MD500-AZJ-A3T10 Guide Rail*.

2 Dimensions Drawings

2.1 T1 to T9 Models

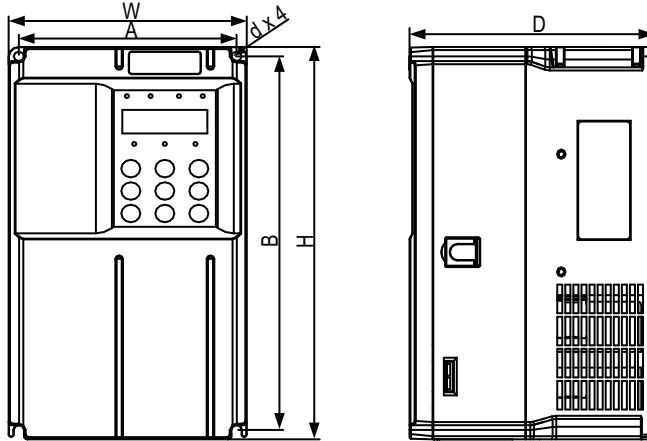

Figure 2-1 Dimension drawing of T1 to T4 models

Table 2-1 Dimensions of T1 to T4 models

Structure	Mounting Hole mm (in.)		Outline Dimensions mm (in.)				Mounting Hole Diameter mm (in.)	Weight kg (lb)
	A	B	H	H1	W	D		
T1	119 (4.7)	189 (7.5)	200 (7.9)	-	130 (5.1)	152 (6.0)	Ø5 (0.2)	1.6 (3.5)
T2	119 (4.7)	189 (7.5)	200 (7.9)	-	130 (5.1)	162 (6.4)	Ø5 (0.2)	2.0 (4.4)
T3	128 (5.0)	238 (9.4)	250 (9.9)	-	140 (5.5)	170 (6.7)	Ø6 (0.2)	3.3 (7.3)
T4	166 (6.5)	266 (10.5)	280 (11.0)	-	180 (7.1)	170 (6.7)	Ø6 (0.2)	4.3 (9.5)

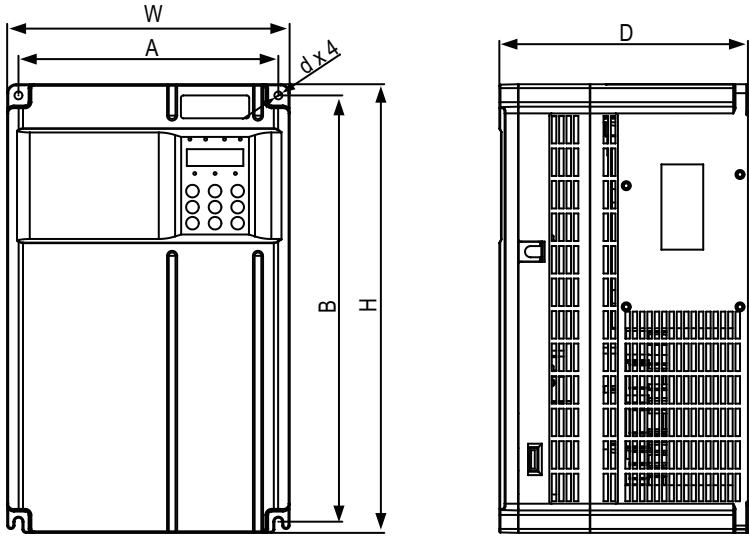

Figure 2-2 Dimension drawing of T5 to T6 models

Table 2-2 Dimensions of T5 to T6 models

Structure	Mounting Hole mm (in.)		Outline Dimensions mm (in.)				Mounting Hole Diameter mm (in.)	Weight kg (lb)
	A	B	H	H1	W	D		
T5 (without DC reactor)	195 (7.7)	335 (13.2)	350 (13.8)	-	210 (8.3)	192 (7.6)	Ø6 (0.2)	7.6 (16.8)
T5 (with DC reactor)	195 (7.7)	335 (13.2)	350 (13.8)	-	210 (8.3)	192 (7.6)	Ø6 (0.2)	10.0 (22.0)
T6	230 (9.1)	380 (15.0)	400 (15.8)	-	250 (9.9)	220 (8.7)	Ø7 (0.3)	17.5 (38.6)

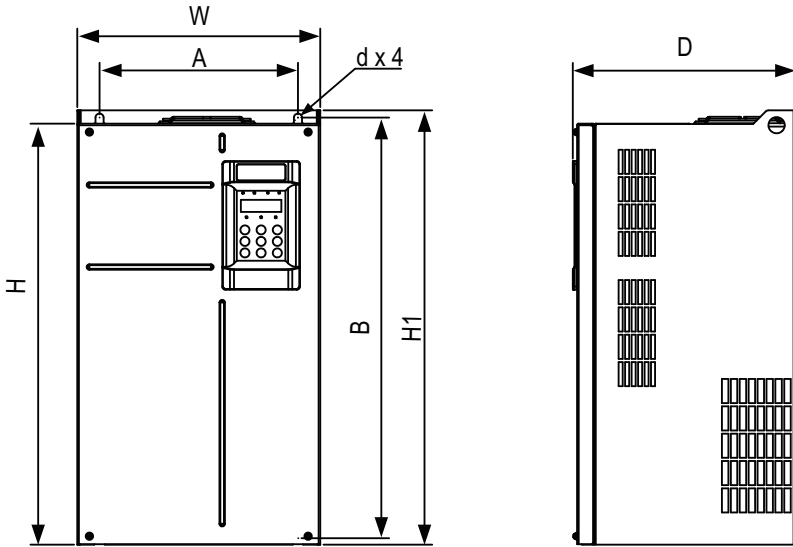

Figure 2-3 Dimension drawing of T7 to T9 models

Table 2-3 Dimensions of T7 to T9 models

Structure	Mounting Hole mm (in.)		Outline Dimensions mm (in.)				Mounting Hole Diameter mm (in.)	Weight kg (lb)
	A	B	H	H1	W	D		
T7	245 (9.7)	523 (20.6)	525 (20.7)	542 (21.4)	300 (11.8)	275 (10.8)	Ø10 (0.4)	35 (77.2)
T8	270 (10.6)	560 (22.1)	554 (21.8)	580 (22.9)	338 (13.3)	315 (12.4)	Ø10 (0.4)	51.5 (113.5)
T9	320 (12.6)	890 (35.1)	874 (34.4)	915 (36.1)	400 (15.8)	320 (12.6)	Ø10 (0.4)	85 (187.4)

2.2 T10 to T12 Models (Without AC Output Reactor)

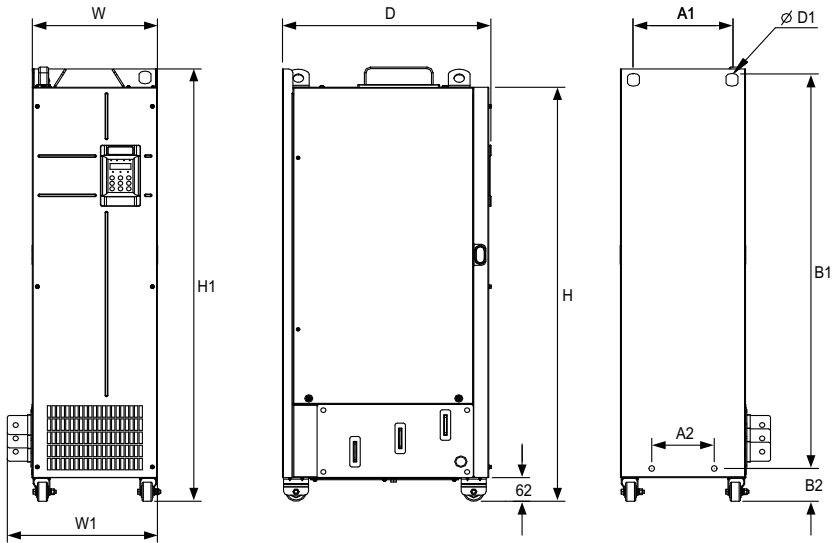

Figure 2-4 Dimension drawing of T10 to T12 models (without AC output reactor)

Table 2–4 Dimensions of T10 to T12 models (without AC output reactor)

Structure	Mounting Hole Spacing mm (in.)				Outline Dimensions mm (in.)					Mounting Hole Diameter mm (in.)	Weight kg (lb)
	A1	A2	B1	B2	H	H1	W	W1	D		
T10	240 (9.5)	150 (5.9)	1035 (40.8)	86 (3.4)	1086 (42.8)	1134 (44.7)	300 (11.8)	360 (14.2)	500 (19.7)	φ13 (0.5)	110 (242.5)
T11	225 (8.9)	185 (7.3)	1175 (46.3)	97 (3.8)	1248 (49.2)	1284 (50.6)	330 (13.0)	390 (15.4)	545 (21.5)	φ13 (0.5)	155 (341.7)
T12	240 (9.5)	200 (7.9)	1280 (50.4)	101 (4.0)	1355 (53.4)	1405 (55.4)	340 (13.4)	400 (15.8)	545 (21.5)	φ16 (0.6)	185 (407.9)

2.3 T10 to T12 Models (with AC Output Reactor)

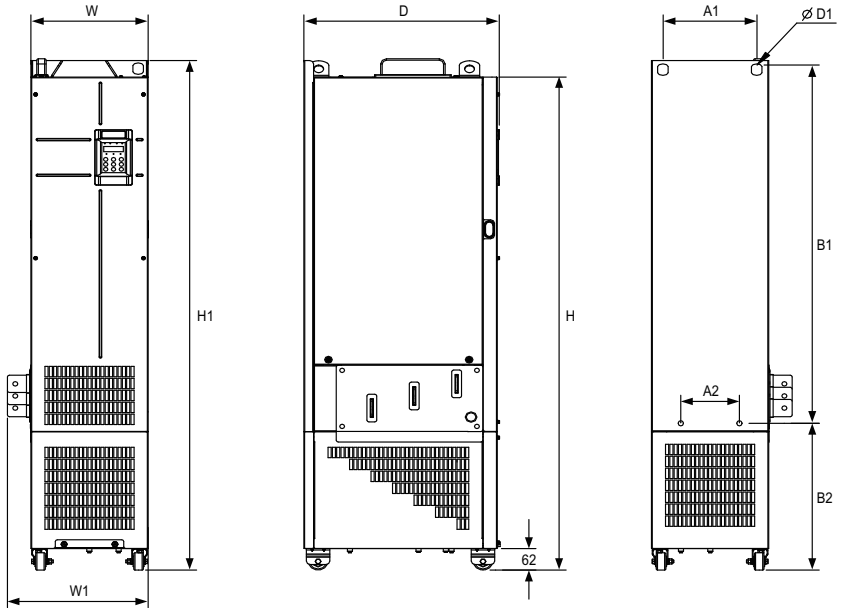

Figure 2-5 Dimension drawing of T10 to T12 models (with AC output reactor)

Table 2-5 Dimensions of T10 to T12 models (with AC output reactor)

Structure	Mounting Hole Spacing mm (in.)				Outline Dimensions mm (in.)					Mounting Hole Diameter mm (in.)	Weight kg (lb)
	A1	A2	B1	B2	H	H1	W	W1	D	D1	
T10	240 (9.5)	150 (5.9)	1035 (40.8)	424 (16.7)	1424 (56.1)	1472 (58.0)	300 (11.8)	360 (14.2)	500 (19.7)	φ13 (0.5)	160 (352.7)
T11	225 (8.9)	185 (7.3)	1175 (46.3)	435 (17.1)	1586 (62.5)	1622 (63.9)	330 (13.0)	390 (15.4)	545 (21.5)	φ13 (0.5)	215 (474.0)
T12	240 (9.5)	200 (7.9)	1280 (50.4)	432 (17.0)	1683 (66.3)	1733 (68.3)	340 (13.4)	400 (15.8)	545 (21.5)	φ16 (0.6)	245 (540.1)

2.4 T13 Models (Without Auxiliary Power Distribution Cabinet)

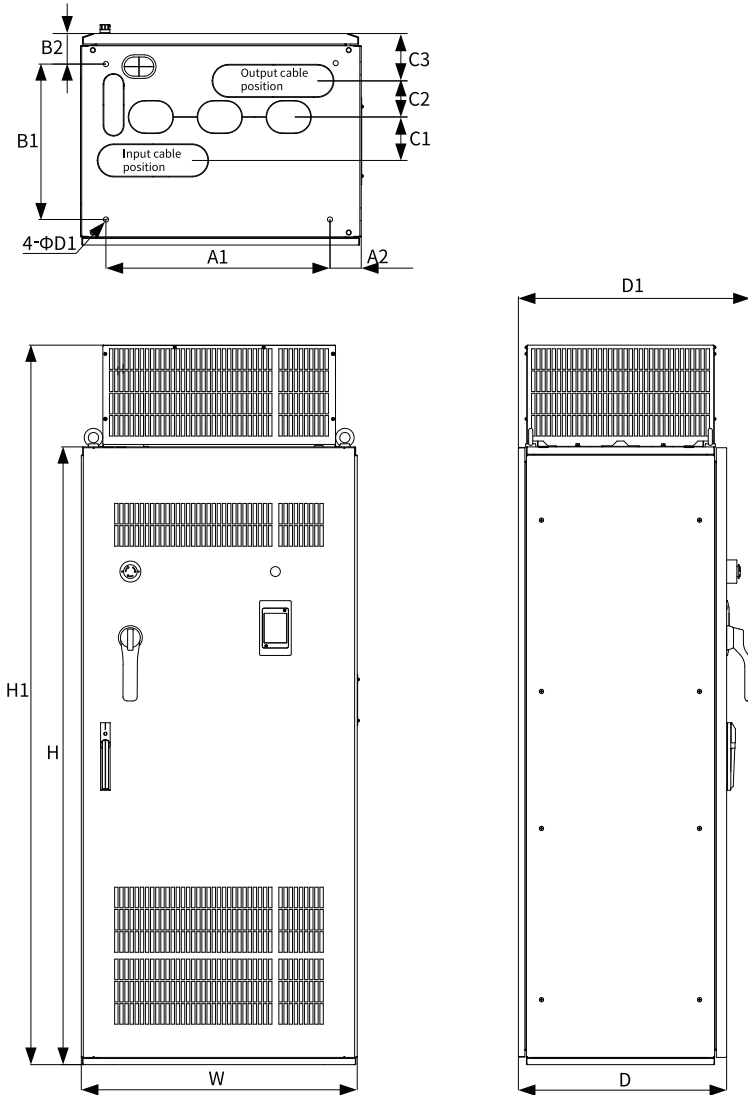

Figure 2-6 Dimension drawing of T13 models (without auxiliary power distribution cabinet)

Table 2-6 Dimensions of T13 models (without auxiliary power distribution cabinet)

Structure	Mounting Hole Spacing mm (in.)							Outline Dimensions mm (in.)					Mounting Hole Diameter mm (in.)	Weight kg (lb)
	A1	A2	B1	B2	C1	C2	C3	H	H1	W	D	D1	D1	
T13	660 (26.0)	73.5 (2.9)	450 (17.7)	85 (3.3)	125 (4.9)	104 (4.1)	136 (5.4)	1800 (70.9)	2100 (82.7)	805 (31.7)	610 (24.0)	680 (26.8)	15 (0.6)	530 (1168.4)

2.5 T13 Models (with Auxiliary Power Distribution Cabinet)

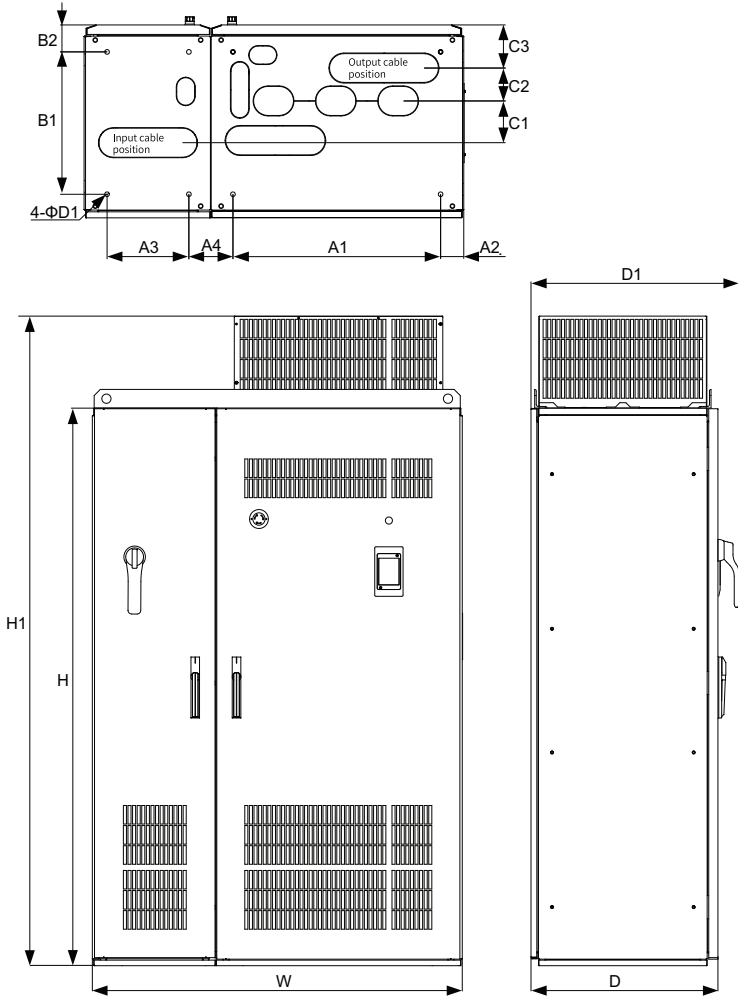

Figure 2-7 Dimension drawing of T13 models (with auxiliary power distribution cabinet)

Table 2-7 Dimensions of T13 models (with auxiliary power distribution cabinet)

Mounting Hole Spacing mm (in.)									Outline Dimensions mm (in.)					Hole Dia. mm (in.)	Wgt. kg (lb)
A1	A2	A3	A4	B1	B2	C1	C2	C3	H	H1	W	D	D1	D1	
660 (26.0)	73.5 (2.9)	260 (10.2)	140 (5.5)	450 (17.7)	85 (3.3)	132 (5.2)	104 (4.1)	136 (5.4)	1800 (70.9)	2100 (82.7)	1205 (47.5)	610 (24.0)	680 (26.8)	15 (0.6)	730 (1609.4)

3 Unpacking and Transportation

3.1 Storage

- Store the AC drive in a clean and dry space, with an ambient temperature ranging from -20°C to $+60^{\circ}\text{C}$ and a temperature change rate less than $1^{\circ}\text{C}/\text{min}$.
- For long time storage, cover the AC drive or take other appropriate measures to keep it from contamination and environmental influences.
- For storage, pack the AC drive with the original packing box provided by Inovance.
- Avoid exposing the AC drive to moisture, high temperature, or outdoor direct sunlight for an extended period.
- To avoid degradation of electrolytic capacitor during long-term storage, energize the AC drive once every six months, each time lasting at least 5 hours. Use a regulator to increase the input voltage gradually to the rated value. For any doubt, contact Inovance.

3.2 Transportation Before Unpacking

T1 to T12 models

Precautions for transportation of T1 to T12 models:

- T1 to T6 models are small and light and therefore can be handled manually. T7 to T12 models, however, must be transported with an appropriate lifting tool.
- Where applicable, fasten the AC drive onto a wooden pallet for transport by a forklift. Where applicable, fasten the AC drive onto a pallet before being lifted by a crane, as shown in the following figure.

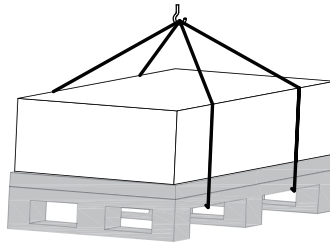
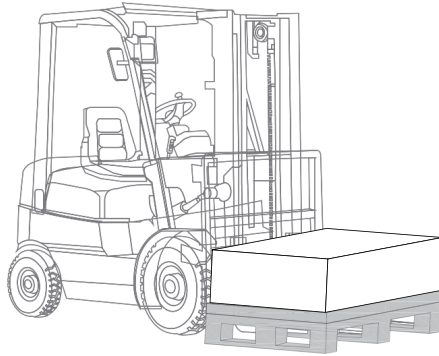

Figure 3-1 Lifting the AC drive

- T9 to T12 models are heavy with a high center of gravity. Therefore, avoid placing them on an inclined surface with an inclination greater than 5 degrees. Place the AC drive on a flat and sturdy floor able to bear the weight of the AC drive.
- Transport the AC drive only when it is upright as indicated on the packaging box, as shown in the following figure.

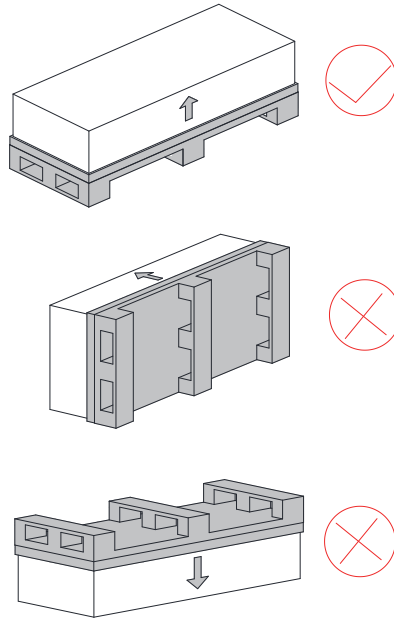

Figure 3-2 Placing the AC drive

T13 models

Precautions for transportation of T13 models:

- The AC drive is heavy with a high center of gravity. Therefore, avoid placing it on an inclined surface with an inclination greater than 5 degrees. Place the AC drive on a flat and sturdy floor able to bear the weight of the AC drive.
- Transport the AC drive only when it is upright as indicated on the packaging box.

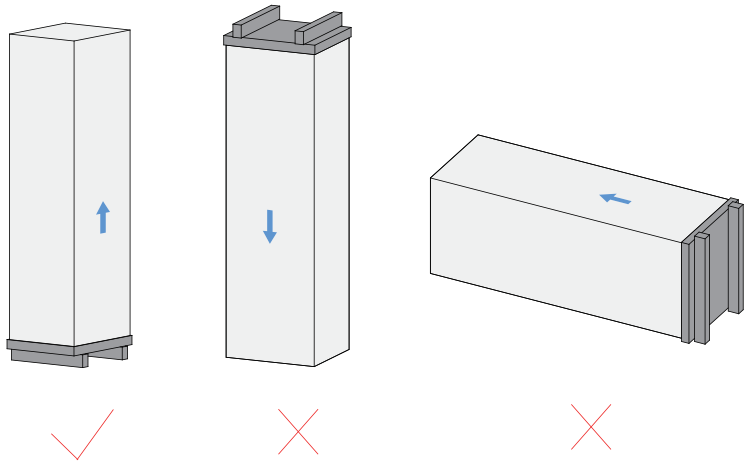

Figure 3-3 Cabinet standing upright

- Use an appropriate lifting tool because the AC drive is heavy. Ensure that the lifting tool is operated by trained personnel.
- Where applicable, use a forklift and a crane that have a carrying capacity greater than the cabinet weight to transport the cabinet.
- Where applicable, fasten the cabinet onto a wooden pallet for transport by a forklift. Keep the cabinet on the pallet until the cabinet no longer needs to be transported. Adjust the spacing between the forks to greater than half the width of the cabinet.
- Considering the weight and width of the cabinet, use the lifting beam (or eye bolts) fixed at its top and the wooden pallet at its bottom to help lift the cabinet. Lift the cabinet with the sling of the crane passing through the pallet and a relief height not exceeding 0.3 m.
- Avoid using hydraulic vehicles for transportation over a long distance or on slope roads.
- Ensure that the cabinet is held by people on the left and right sides when being moved.

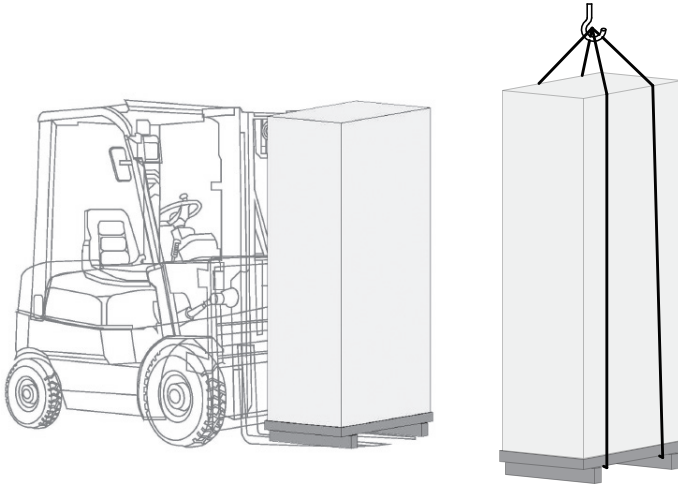

Figure 3-4 Moving the AC drive before unpacking

3.3 Packing Verification

Upon receipt from the shipping company, check that you have received all the items specified on the delivery note. Notify the shipping company immediately of any missing or damaged items. If necessary, request the support of Invoice office or your local agent.

AC drives of different structural dimensions are different in size and weight, and hence are packed in different methods with different components incorporated.



The electrical safety performance of the AC drive may be affected if it is damaged during transportation. Avoid connecting the AC drive without a professional high-voltage test on it.

Packing list for T1 to T9 models

- T1 to T6 models are packed using cartons.
- T7 to T9 models are packed using cartons and plywood pallets.

The packing contents are as follows:

- Packing list for T1 to T6 models

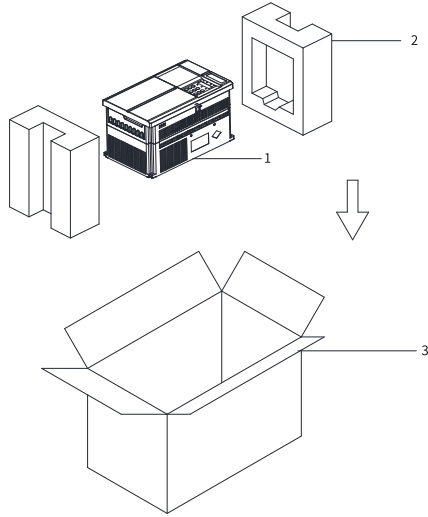

Figure 3-5 Packing list for T1 to T6 models

No.	Name
1	AC drive
2	Cushion
3	Carton

● Packing list for T7 to T9 models

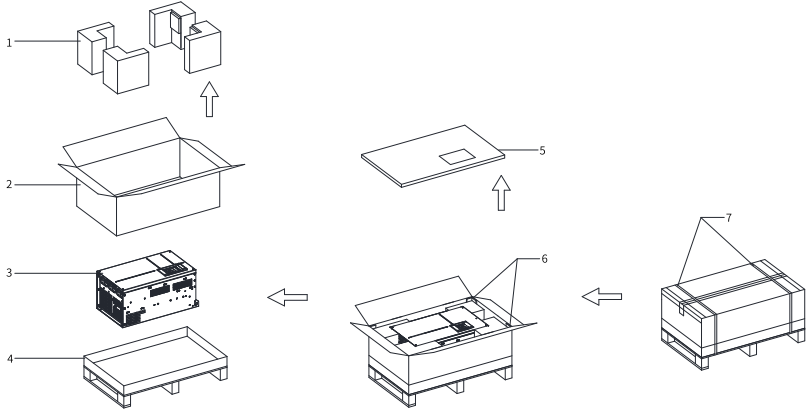

Figure 3-6 Packing list for T7 to T9 models

No.	Name
1	Cushion
2	Carton

No.	Name
3	AC drive
4	Plywood pallet
5	Honeycomb cardboard
6	Paper corner protector
7	Tie

Packing list for T10 to T12 models

- T10 to T11 models are packed using cartons and plywood pallets.
- T12 models are packed using wooden crates.

The package contents are as follows:

- Packing list for T10 models

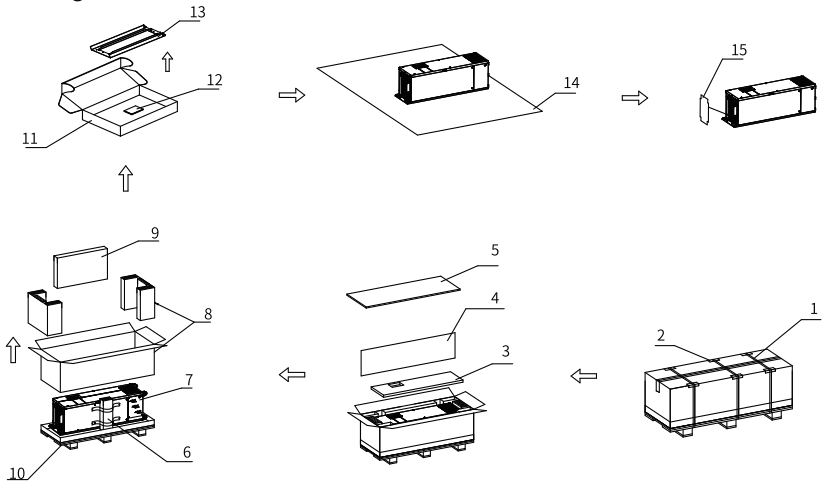

Figure 3-7 Packing list for T10 models

No.	Name
1	Packing belt
2	Paper corner protector
3	Honeycomb cardboard
4	Corrugated cardboard
5	9 mm board
6	Paper column
7	AC drive
8	Carton
9	Bracket box
10	Wooden pallet

No.	Name
11	Carton
12	User guide
13	Bracket
14	Plastic bag
15	Corrugated cardboard

● Packing list for T11 models

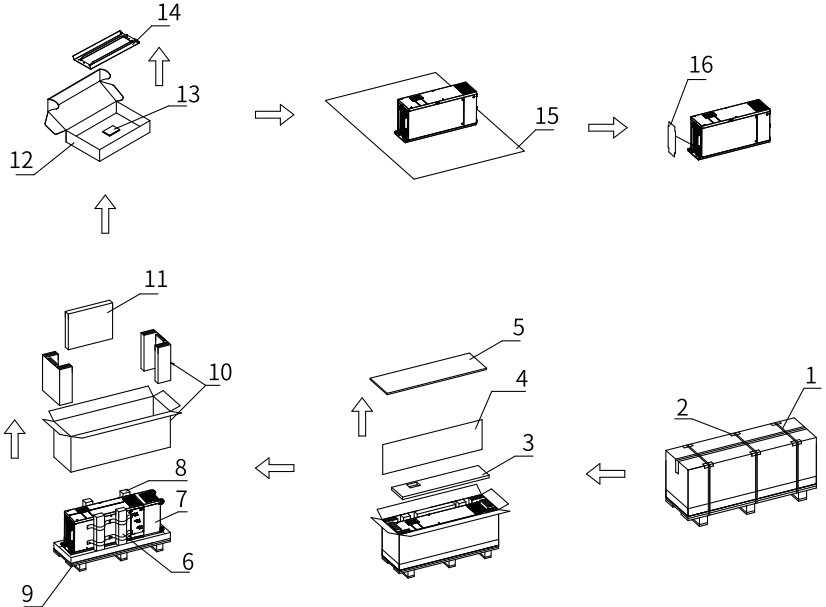

Figure 3-8 Packing list for T11 models

No.	Name
1	Packing belt
2	Paper corner protector
3	Honeycomb cardboard
4	Corrugated cardboard
5	9 mm board
6	Paper column
7	AC drive
8	Paper column
9	Wooden pallet
10	Carton
11	Bracket box

No.	Name
12	Carton
13	User guide
14	Bracket
15	Plastic bag
16	Corrugated cardboard

● Packing list for T12 models

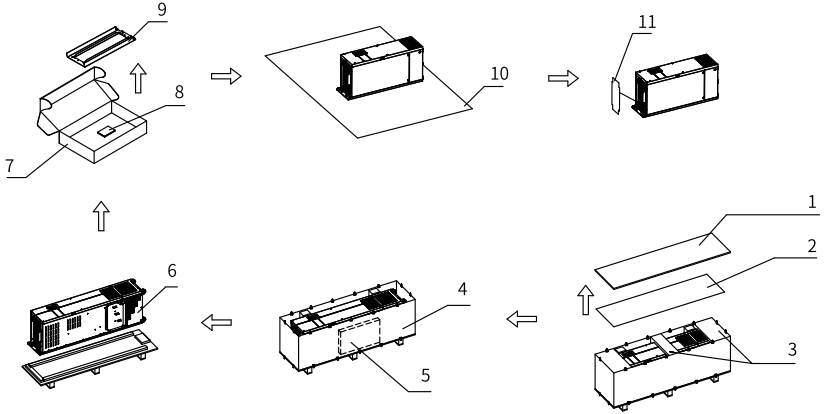

Figure 3-9 Packing list for T12 models

No.	Name
1	Cover
2	Corrugated cardboard
3	Expanded polyethylene
4	Wooden crate
5	Bracket box
6	MD500-PLUSAC drive
7	Carton
8	User guide
9	Bracket
10	Plastic bag
11	Corrugated cardboard

Packing list for T13 models

T13 models are with a standard cabinet or a cabinet with an auxiliary power distribution cabinet. The package contents are shown as follows.

● Packing list for a T13 model provided with a standard cabinet

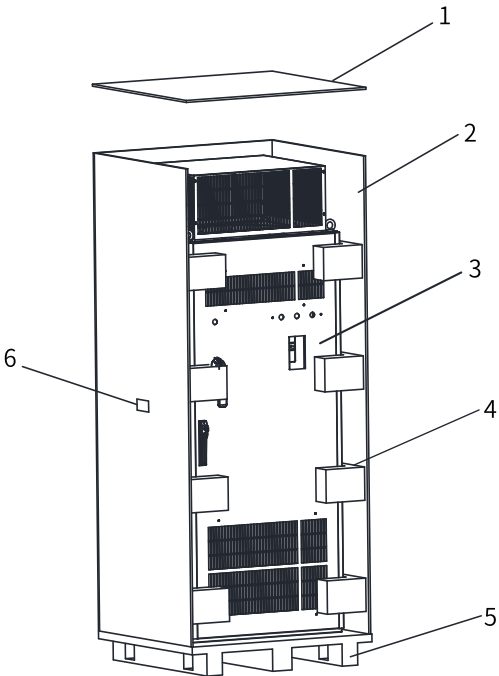

Figure 3-10 Packing list for a T13 model provided with a standard cabinet

No.	Name
1	Cover
2	Wooden crate
3	AC drive
4	Expanded polyethylene
5	Base
6	Anti-inclination label

- Packing list for a T13 model provided with a cabinet and an auxiliary power distribution cabinet

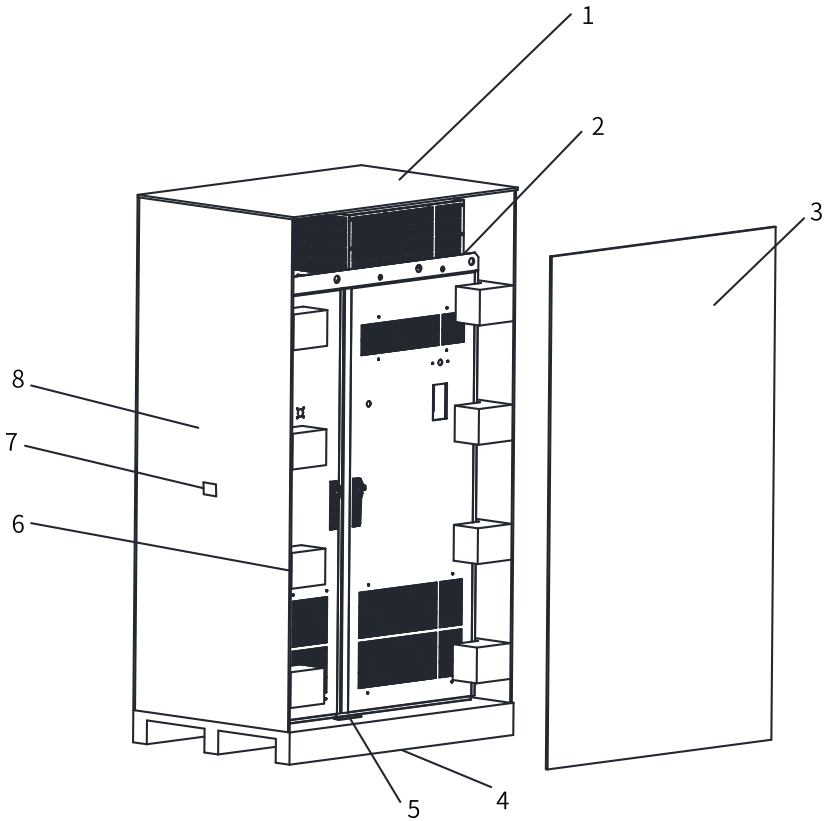

Figure 3-11 Packing list for a T13 model provided with a cabinet and an auxiliary power distribution cabinet

No.	Name
1	Cover
2	AC drive
3	Front panel
4	Base
5	Plywood
6	Expanded polyethylene
7	Anti-inclination label
8	Side panel

3.4 Unpacking

T1 to T12 models

The document suite and accessories are placed in different partitions in the crate. Observe the following steps to unpack the AC drive:

1. Remove all ties and take off the cover.
2. Remove all filling materials.
3. Take out the AC drive.
4. Remove the plastic wrap around the AC drive by cutting.
5. Check that there is no damage.
6. Dispose of or recycle the packaging in accordance with local regulations.

T13 models

1. During unpacking, put the claw bar into the wooden crate case as short as possible to prevent damaging the cabinet. Exercise caution to avoid injury by iron nails.
2. When removing the inner packing materials such as plastic film, use no sharp tools to avoid scratching the cabinet.
3. Place a well-packaged product in an open and flat workshop and use an iron claw bar to pry off the wooden crate carefully. Then, remove the cover and the side and end plates.

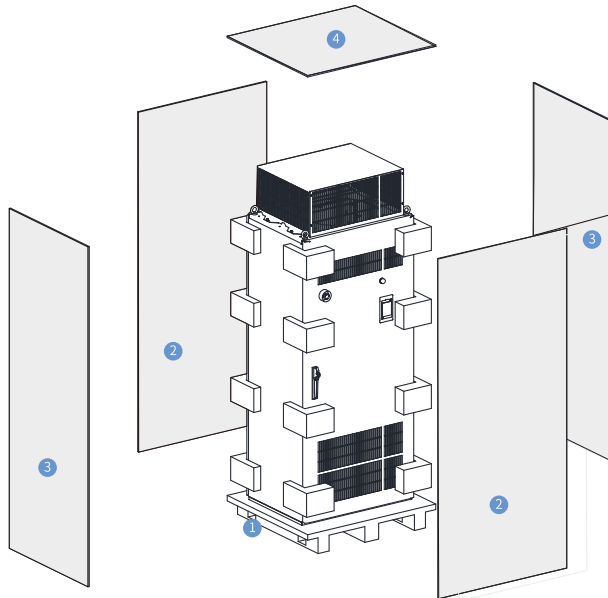

Figure 3-12 Unpacking the AC drive

Note

Dispose of the packaging materials in accordance with applicable local regulations.

3.5 Transportation and Lifting After Unpacking

T1 to T6 models are small and light and therefore can be handled manually. T7 to T13 models, however, must be transported with an appropriate lifting tool.

Weight of AC Drive	Number of Persons Required
< 15 kg	1
≥ 15 kg	> 2; with an appropriate lifting device

Precautions for transportation and lifting:

- Comply with local regulations.
- Avoid handling the AC drive by directly holding its upper access cover or enclosure. Before moving it, check that all screws have been tightened. Failure to comply may result in physical injury by the AC drive falling because of loose screws.
- For T10 to T12 models, when fastening the AC drive, ensure that the four backplate mounting holes on the back of the AC drive are securely connected to the fixing beam.
- Erect the AC drive that is lying flat before lifting or moving it.
- Use a crane whose carrying capacity is greater than the weight of the AC drive, where appropriate.
- Before a vertical lift, check that all components of the AC drive including the upper access cover and terminals have been securely fixed with screws. Failure to comply may result in physical injury due to falling of the AC drive.
- When lifting the AC drive with a lifting rope, avoid subjecting the AC drive to excessive vibration or impact. Failure to comply may result in physical injury due to falling of the AC drive.
- When lifting the AC drive with a lifting rope, do not turn the AC drive or leave it suspended a long time. Failure to comply may result in physical injury due to falling of the AC drive.

T1 to T9 models

Lifting steps for T1 to T9 models:

1. Attach the hooks of the lifting rope to the two auxiliary eye bolts at the top of the AC drive.

It is recommended that the lifting angle be above 45 degrees and that the relief height not exceed 0.3 m.

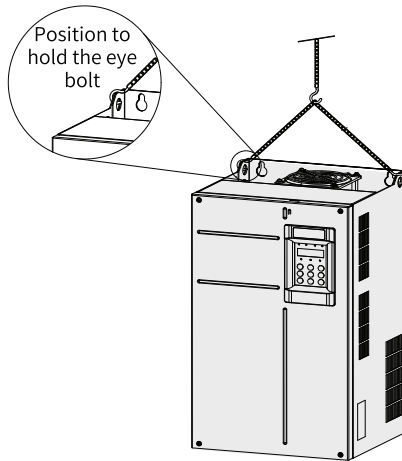

Figure 3-13 Lifting the T1 to T9 models

2. Slowly roll up the lifting rope with a crane until the rope is tight, and then lift the AC drive.
3. Slowly lower the load and suspend it after it descends to a certain height. Then slowly place the AC drive on the floor or mounting surface, and install it in the control cabinet.

T10 to T12 models

Lifting steps for T10 to T12 models:

1. Hook the lift fitting parts at the top and bottom of the AC drive, take out the AC drive from the packing box, and lay it flat on the floor.
Ensure that there is no stress on the positive and negative bus terminals.

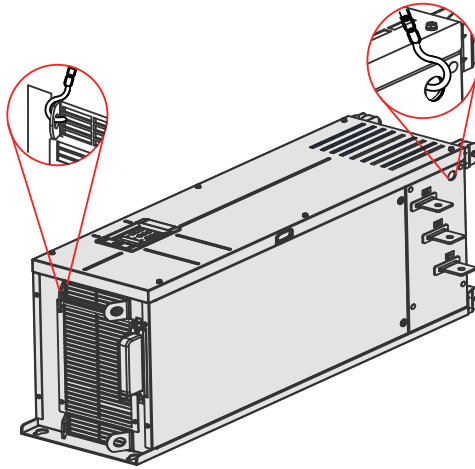

Figure 3-14 Lifting the T1 to T9 models

2. Hook the lifting lugs at the top of the AC drive with a lifting rope to do a diagonal lift, slowly set the AC drive upright, and install it inside the cabinet.



Avoid stress on any side of the AC drive or placing it on an inclined surface. The AC drive is large and heavy (close to 200 kg). If the inclination exceeds 5°, it may topple.

T13 models

1. Before installation, remove the fixing screws from the four corners of the transportation pallet and the cabinet, and remove the pallet.

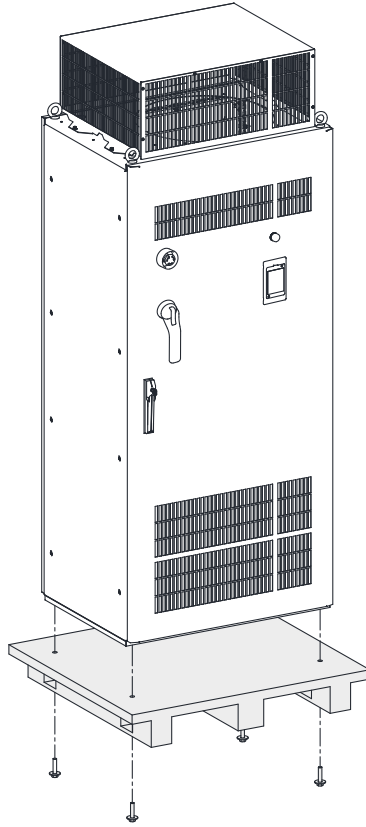

Figure 3-15 Unloading the cabinet from the pallet

2. Transport the cabinet with a crane whose carrying capacity is greater than the cabinet weight.
3. Lift and move the AC drive using the auxiliary angle bars or auxiliary eye bolts at the top the cabinet, with a relief height kept within 0.3 m.
4. Ensure that the cabinet has been locked before moving.
5. Ensure that the cabinet is held by people on the left and right sides when being moved.

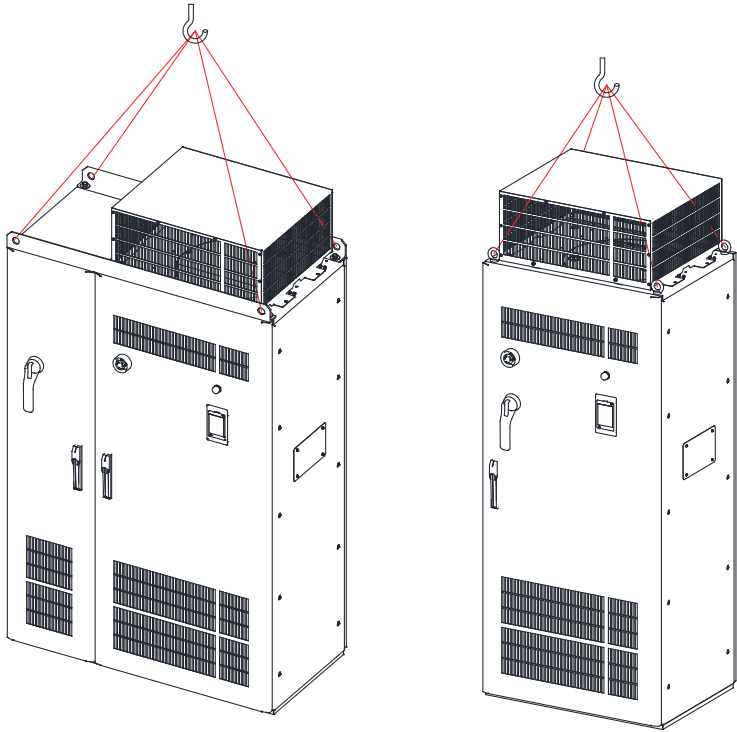

Figure 3-16 Transportation after unpacking

4 Mechanical Installation (T1 to T9 Models)

4.1 Installation Method

T1 to T9 models support backplate mounting and through-hole mounting.

4.2 Cabinet Design

4.2.1 Overview

Before installing the AC drive in the cabinet, design the cabinet to ensure sufficient clearances for installation and heat dissipation. Take the following factors into consideration:

- Cabinet clearances
- Mounting backplate
- Cabinet heat dissipation

4.2.2 Cabinet Clearance Requirements

For T1 to T9 models, install one AC drive above another. The following table lists the minimum requirements for clearance between AC drives. Install an air guide plate on each AC drive except for the top one.

Table 4-1 Minimum clearance for installing one AC drive above another

Item	T1 to T4	T5	T6	T7 to T9
S1	≥ 100 mm	≥ 200 mm	≥ 200 mm	≥ 300 mm
S2	≥ 100 mm	≥ 200 mm	≥ 200 mm	≥ 300 mm
...	≥ 100 mm	≥ 200 mm	≥ 200 mm	≥ 300 mm
Sn	≥ 100 mm	≥ 200 mm	≥ 200 mm	≥ 300 mm

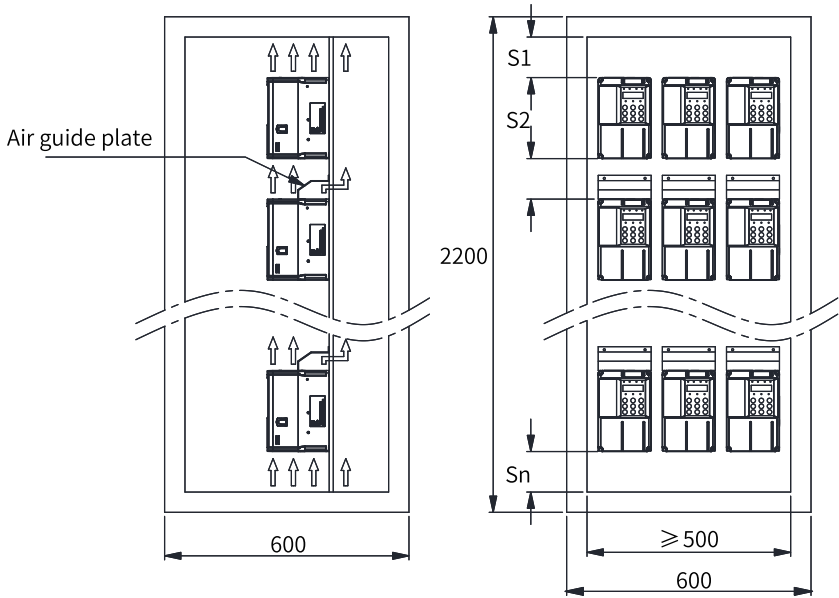

Figure 4-1 Minimum clearance for installing one AC drive above another

Note

Observe the ventilation direction when installing the fan to ensure smooth discharge of hot air. Failure to comply may cause failure in hot air exhaust, and over-temperature or damage to the AC drive. Ensure a distance of at least 200 mm between the air exhaust top cover and the fan outlet to avoid adverse effect on the cooling performance of the fan.

4.2.3 Mounting Backplate

Thickness and rigidity reinforcement of a mounting backplate

To avoid damage to the AC drive during transportation and ensure proper operation of the AC drive, use a mounting plate with sufficient rigidity and strength, and a thickness of at least 2 mm. Reinforce the backplate where appropriate. For example, weld a lateral reinforcing beam on the back of the backplate, as shown in the following figure.

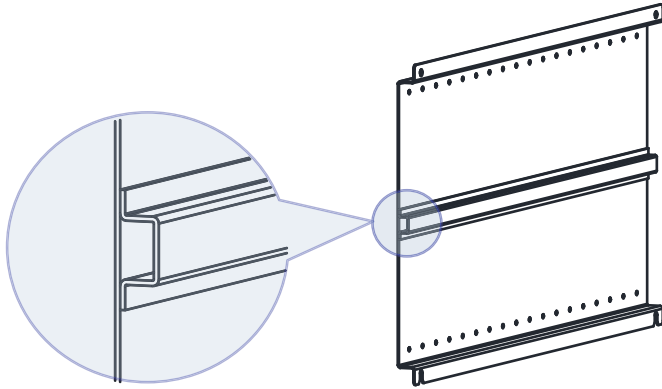

Figure 4-2 Welding a lateral reinforcing beam on the back of the backplate

Preparation of mounting holes

- Prepare mounting holes at the same time with backplate processing. For dimensions of the mounting holes, see "Overall Dimensions".
- To avoid damage to the AC drive during transportation, in addition to fixing screws, use self-clinching nuts or independent nuts on the back of the backplate to enhance screw-thread fitting and fastening effect.

4.2.4 Cabinet Heat Dissipation Design

Heat dissipation design for the cabinet door

Forced-air cooling is implemented using the built-in fan for the AC drive. Provide an air inlet with an appropriate size on the cabinet door to ensure enough cooling air entering the cabinet.

The air flows upward due to thermal expansion. Therefore, ensure that the cabinet air inlet is at least 50 mm lower than the air inlet of the AC drive, as shown in the following figure.

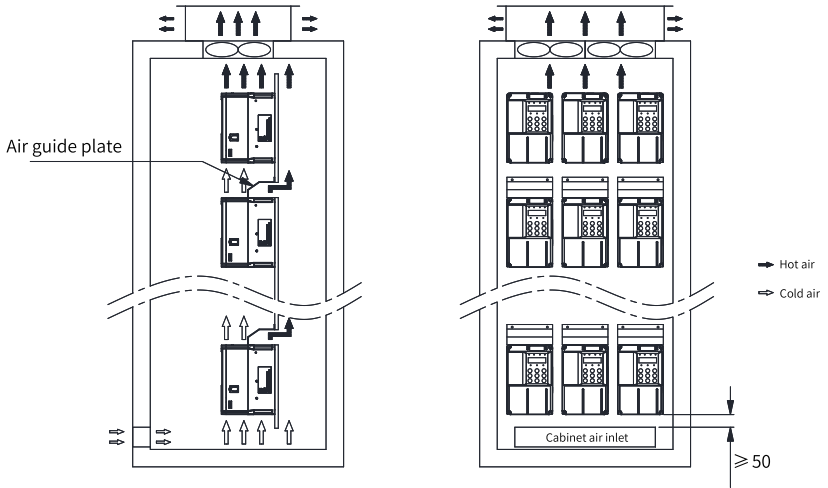

Figure 4-3 Position of the cabinet air inlet

Note

For a cabinet that holds multiple AC drives, blowing air into the cabinet using a fan at the air inlet may disturb the air distribution in the cabinet, affecting the overall cooling effect. Therefore, do not install any fan at the cabinet air inlet.

For the minimum effective area of the air inlet after the AC drive is installed into the cabinet, see ["Table 4-2 Minimum effective area of the cabinet air inlet" on page 66](#).

Table 4-2 Minimum effective area of the cabinet air inlet

AC Drive	Minimum Effective Area of the Cabinet Air Inlet (cm ²)
T1	20
T2	25
T3 (7.5 kW)	
T3 (11 kW)	50
T4	
T5	60
T6 to T7	102
T8	204
T9	318

"Table 4–2 Minimum effective area of the cabinet air inlet" on page 66 applies to situations where only one AC drive is mounted in the cabinet. For a cabinet containing multiple AC drives, calculate the total effective inlet area by summing each single effective area according to the table. For example, if a cabinet contains eight 7.5 kW T3 models, two T5 models, and one T9 model, the minimum effective area of the air inlet is $8 \times 25 + 2 \times 60 + 1 \times 318 = 638 \text{ cm}^2$.

If an air filter is installed at the air inlet, the air inlet resistance will rise significantly and the ventilation opening area must be increased to 1.2–1.5 times the value indicated in the table.

"Table 4–2 Minimum effective area of the cabinet air inlet" on page 66 refers to the actual through-hole area in the cut-out area. The effective area is calculated by multiplying the cut-out area by the cut-out rate.

Design of top ventilation

Ensure smooth discharge of hot air from the cabinet to the outside to keep sufficient heat dissipation for the AC drive. Use passive or active ventilation design for the cabinet.

1. Passive ventilation (self-ventilated)

In passive ventilation, hot air that flows upward is guided to the air outlet on the top of the cabinet.

In passive ventilation, hot air may accumulate at the top of the cabinet, resulting in increased air pressure at the top. At the same time, the air pressure at the cabinet air inlet is low due to the suction of the AC drive fan. Therefore, there is an air pressure difference between the inside, air outlet, and air inlet of the cabinet, causing air flow. The hot air at the air outlet is forced to flow toward the air inlet and then be taken into the AC drive again, causing a great temperature rise of the AC drive and adversely affecting the performance of the AC drive.

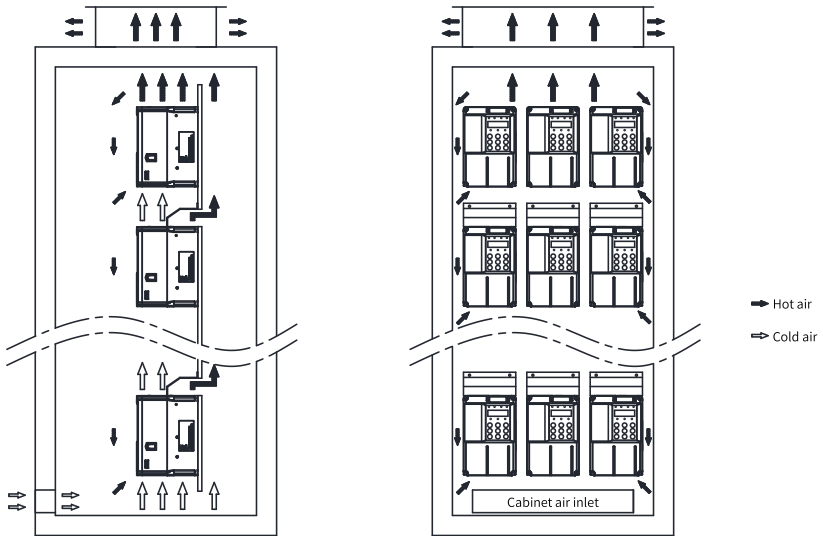

Figure 4-4 Backflow of hot air in a self-ventilated cabinet (without an isolating device)

To prevent backflow of hot air, use an isolating device in the self-ventilated cabinet. An isolating device may be a plate or an exhaust duct.

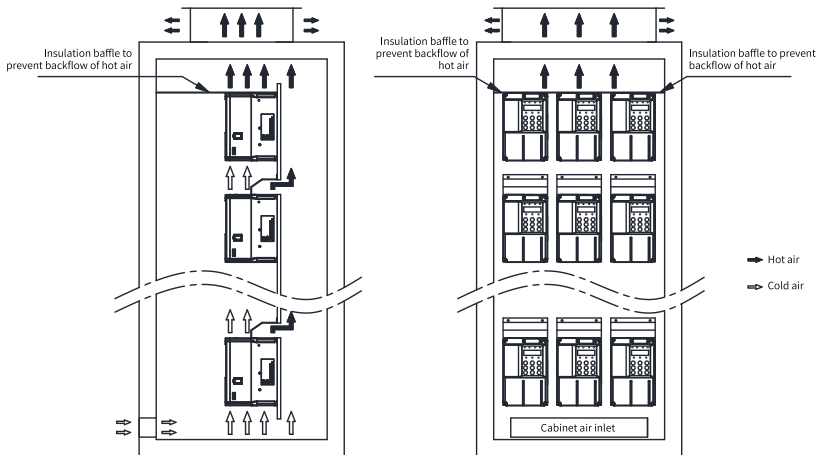

Figure 4-5 Backflow of hot air in a self-ventilated cabinet (with an isolating device)

Compared with the air inlet, the air outlet of the AC drive has a higher air temperature and a lower air density. In passive ventilation, ensure enough effective area of the cabinet air outlet. For minimum requirements, see ["Table 4-3 Minimum effective area of air outlet on a self-ventilated cabinet"](#) on page 69.

Table 4–3 Minimum effective area of air outlet on a self-ventilated cabinet

AC Drive	Minimum Effective Area of Air Outlet on a Self-ventilated Cabinet (cm ²)
T1	32
T2	40
T3 (7.5 kW)	
T3 (11 kW)	80
T4	
T5	96
T6 to T7	163
T8	326
T9	509

"Table 4–3 Minimum effective area of air outlet on a self-ventilated cabinet" on page 69 Data shown in the preceding table applies to situations where only one AC drive is mounted in the cabinet. For a cabinet containing multiple AC drives, calculate the total effective outlet area by summing each single effective area according to the table.

If an air filter is installed at the outlet, the air outlet resistance will rise significantly and the ventilation opening area must be increased to 1.2–1.5 times the value indicated in the table.

"Table 4–3 Minimum effective area of air outlet on a self-ventilated cabinet" on page 69 Effective area in the preceding table refers to the actual through-hole area of an opening. The effective area is calculated by multiplying the opening area by the cut-out rate.

2. Active ventilation

In active ventilation, a fan is installed on the top of the cabinet to draw hot air out of the cabinet. Active ventilation is commonly used.

For smooth discharge of hot air, ensure that the overall exhaust air flow of the cabinet is greater than the sum of exhaust air flow of all the AC drives in the cabinet. MD500-PLUS *"Table 4–4 Cooling air flow for the AC drive" on page 69* lists the required cooling air flow.

Table 4–4 Cooling air flow for the AC drive

AC Drive Power	Cooling Air Flow for the AC Drive (CFM)
0.4–1.1 kW	/
1.5–3.0 kW	11
3.7 kW	20
5.5 kW	24
7.5 kW	29
11–15 kW	50

AC Drive Power	Cooling Air Flow for the AC Drive (CFM)
18.5 kW	52
22 kW	58
30 kW	130
37 kW	102
45–55 kW	125
75–90 kW	225
110 kW	350
132 kW	541
160 kW	620
Note: 1 CFM = 0.02832 m ³ /min	

Cabinet fan design

Cabinet fan selection procedure:

1. Calculate the sum of cooling air flow required by all the AC drives based on "[Table 4-4 Cooling air flow for the AC drive](#)" on page 69.
2. Determine the maximum air flow (Q_{max}) of the cabinet.
3. Determine the specifications and quantity of fans according to the maximum air flow (Q_{max}).

Note that:

Maximum air flow of the cabinet = 1.3...1.5 x Sum of cooling air flow

Maximum air flow of the cabinet = 1.6...2.2 x Sum of cooling air flow (for applications with a dry net shutter, or other components installed at the cabinet air outlet)

Note

Select a fan whose air volume is not smaller than the maximum air volume Q_{max}. Install multiple fans in parallel if one fan alone cannot meet the requirements.

The following figure shows typical fan air flows.

Air flow		Nominal voltage	Frequency	Sound pressure level	Sound power level	Sinter sleeve bearings Ball bearings	Power input	Nominal speed	Temperature range	Service life L ₁₀ at 40 °C		Curve
m ³ /h	CFM									V	Hz	
320	188,3	230	50	51	6,4	■	27,0	2 800	-25...+55	60 000 / 32 000	1	
380	223,6	115	60	56	6,8	■	28,0	3 350	-25...+65	55 000 / 18 000	2	

CFM: maximum air flow of the fan (Q_{max})

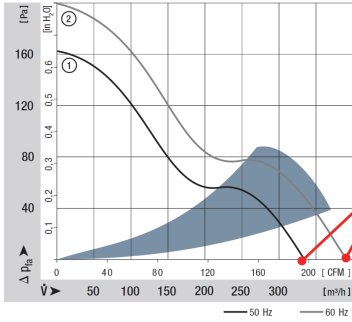

Maximum air flow of the fan (Q_{max})

Figure 4-6 Q_{max} of a system fan

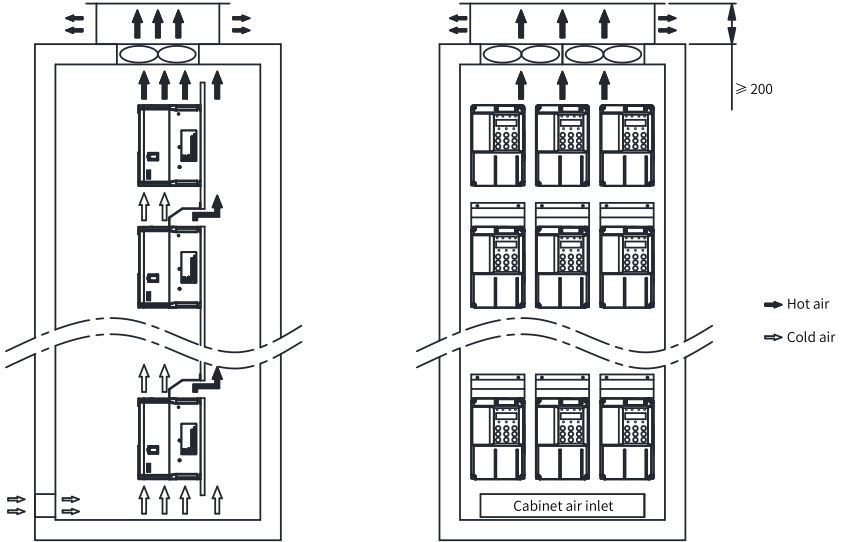

Figure 4-7 Cabinet ventilation system

Note

Observe the ventilation direction when installing the fan to ensure smooth discharge of hot air. Failure to comply may cause failure in hot air exhaust, and over-temperature or damage to the AC drive.

Ensure a distance of at least 200 mm between the air exhaust top cover and the fan outlet to avoid adverse effect on the cooling performance of the fan.

4.3 Installation Precautions

- Before installation, ensure that the mounting position has sufficient mechanical strength to bear the weight of the AC drive.
- Cover the top of the AC drive with cloth or paper during installation to prevent metal cuttings, oil, and water from entering during drilling. Foreign objects entering may cause malfunction of the AC drive. Remove the cloth or paper after the installation is completed. Failure to comply may degrade ventilation and result in unexpected heat.
- Reserve sufficient clearance for heat dissipation, including the heat dissipation of other equipment in the cabinet. For details, see "Installing one alone" in ["1.2.2 Clearances" on page 17](#).
- Keep the equipment upright to help dissipate heat upward. To install multiple AC drives in one cabinet, arrange them side by side. Where up and down arrangement is required, install an air guide plate in between. For details, see "Installing one above another" in ["1.2.2 Clearances" on page 17](#).
- Use a mounting bracket that is flame retardant, where appropriate.
- For environments with metal dust, use a cabinet that can completely enclose the AC drive to isolate the AC drive from metal dust. In this case, as much space as possible should be provided in the fully sealed cabinet, and it is recommended that the radiator be installed outside the cabinet.
- Tighten all screws using the specified torque. Failure to comply may result in electric shock or fire.
- Keep combustible and explosive materials away from the AC drive.

4.4 Backplate Mounting

In this mode, avoid fastening only the two retaining nuts on the top of the AC drive lest the joints come loose or damaged after long-time operation due to the action of unbalanced force.

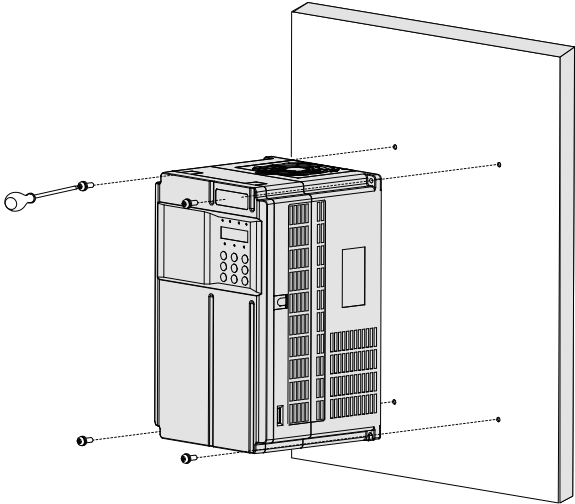

Figure 4-8 Backplate mounting (T1 to T6 models)

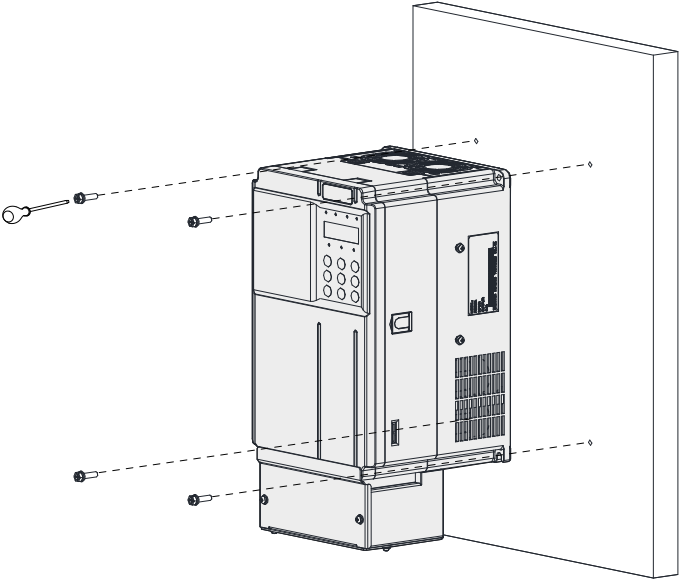

Figure 4-9 Backplate mounting (T1 to T6 models, with conduit boxes)

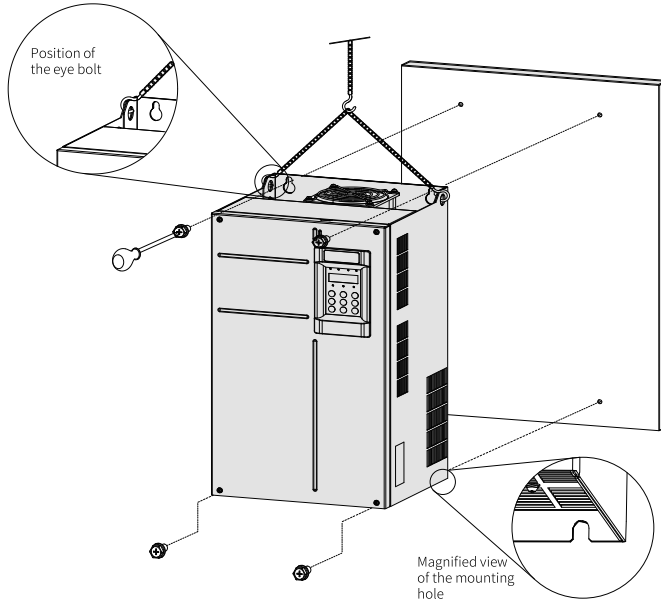
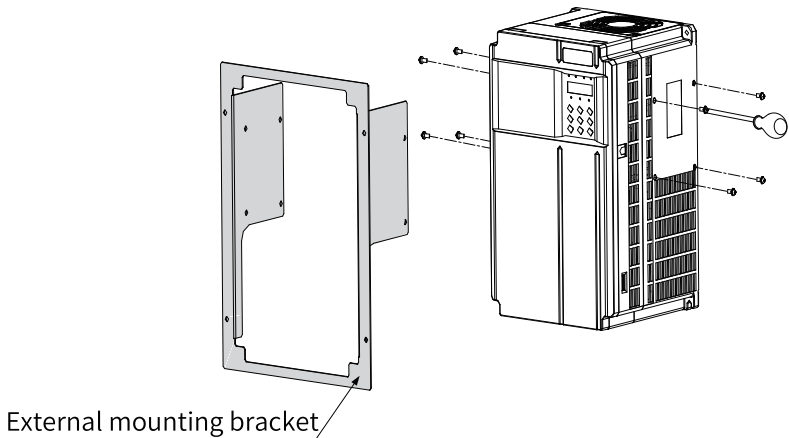

Figure 4-10 Backplate mounting (T7 to T9 models)

4.5 Through-Hole Mounting

1. T1 to T6 models:

- a. Put the bracket around the AC drive, and tighten the bracket fixing screws on the left and right sides of the AC drive.



The following figure shows an AC drive with a bracket mounted.

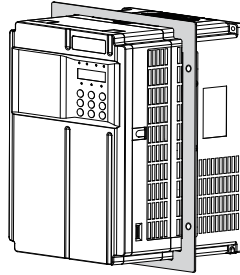

- b. Fasten the AC drive with the bracket mounted onto the mounting backplate of the control cabinet.

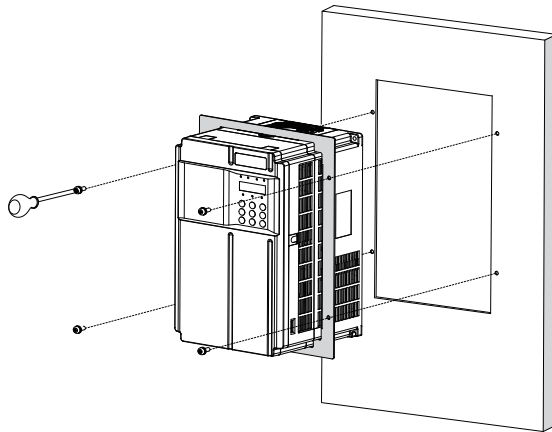

The following figure shows an AC drive that is through-hole mounted.

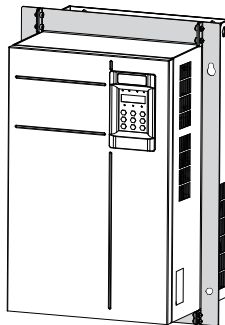

2. T7 to T9 models:

- a. Fasten brackets to the two sides of the AC drive.

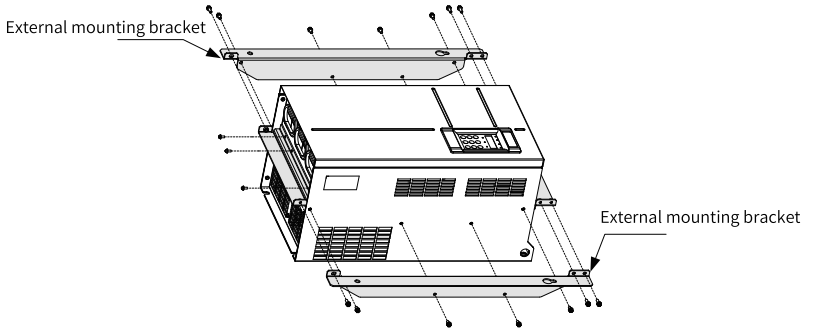

The following figure shows an AC drive with brackets mounted.

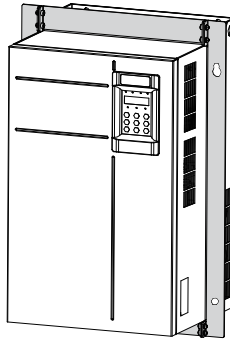

- b. Fasten the AC drive onto the backplate of the control cabinet from the front of the control cabinet.

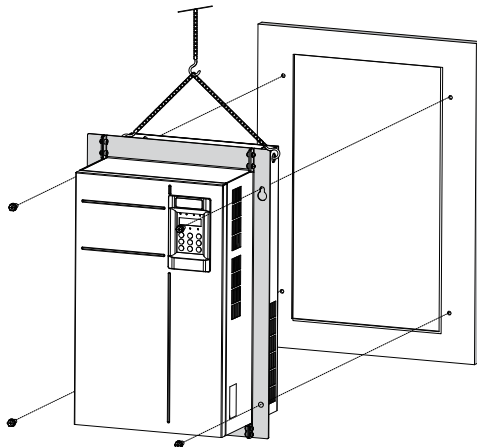

The following figure shows an AC drive that is through-hole mounted.

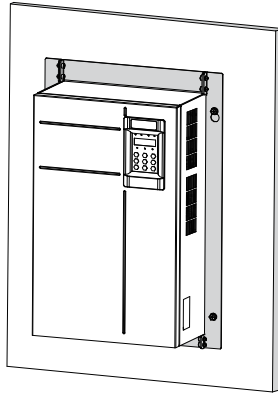

4.6 Removing and Installing the Cover

4.6.1 Removing the Cover

When wiring the control circuit, remove the cover before proceeding with any jumper operation or connecting any PG card or extension card. When removing the cover, hold the cover with your hands and carefully lift the lower part of the cover to prevent the cover from falling off. Failure to comply may result in equipment damage or human injury.

Prerequisites

Before removing the cover, ensure that the AC drive has been powered off for longer than 10 minutes.

Context

The following figure shows the positions of the control board, jumper and extension card with the cover removed.

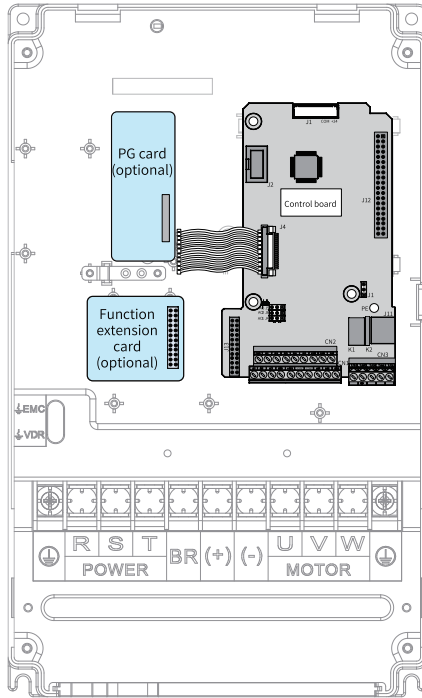
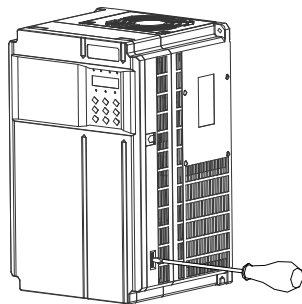

Figure 4-11 Position of the control board

1. T1 to T6 models

- a. Use appropriate tools to eject the cover hooks on both sides to the inside.



- b. Hold the cover with your hands, lift the lower part of the cover (as shown in ①), push the cover upward, and lift the upper part of the cover (as shown in ②).

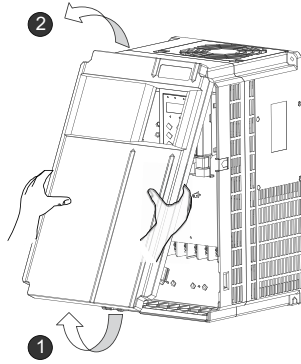

The following figure shows an AC drive with its cover removed.

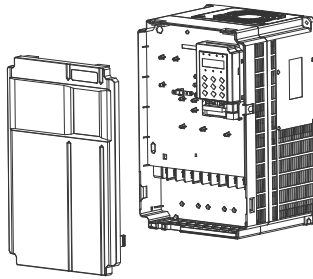

2. T7 to T9 models

- a. Use a screwdriver to unscrew the four fixing screws of the cover.

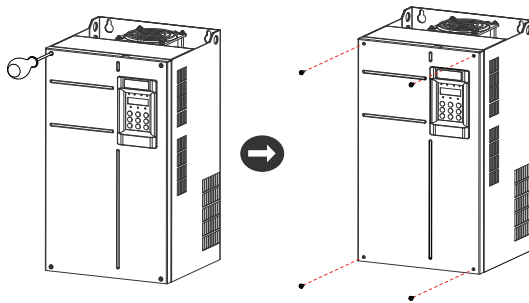

- b. Hold the cover with your hands, and lift it in the arrow direction to remove it.

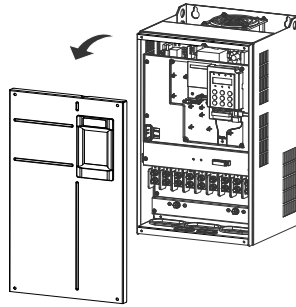

4.6.2 Installing the Cover

MD500-PLUS Remove the cover before wiring the main circuit and control circuit. After the wiring is completed, install the cover back.

1. T1 to T6 models

- a. Hold the cover with your hands and press the snap on the upper edge of the cover into the snap hole.

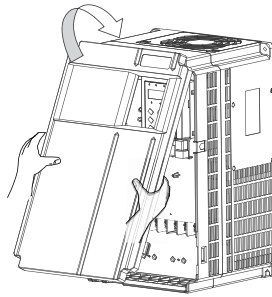

- b. After the cover is aligned, press down the lower edge of the cover in the arrow direction.

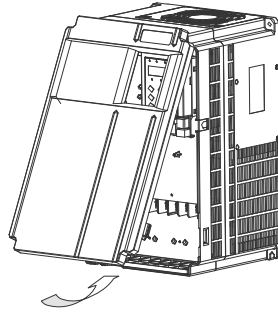

2. T7 to T9 models

- a. Hold the cover with your hands, align the upper edge of the cover with the upper edge snap on the chassis, and snap them together, with the snap-fit joint in the position shown in the following figure.

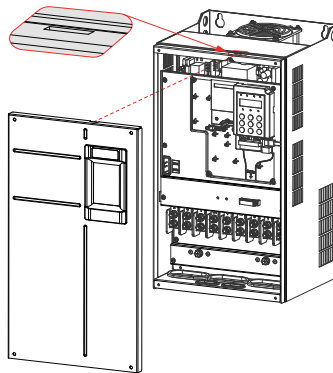

- b. Drive four fixing screws into the mounting holes with a screwdriver.

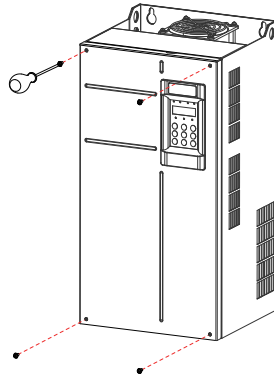

4.7 Installing the Grounding Bracket of Cable Shield

The grounding bracket of cable shield is optional and can be purchased separately (applicable to T9 models and below).

Installation

Table 4-5 Procedure of installing the grounding bracket of cable shield

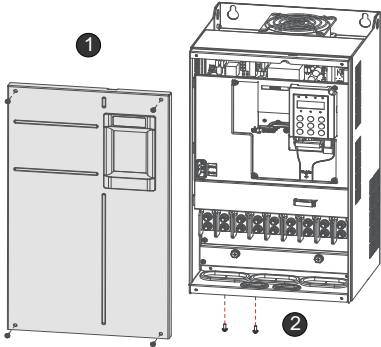
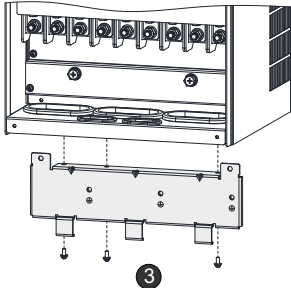
Step	Description	Diagram
1	Remove the cover, as shown in ①. Remove the two M4 x 12 SMES screws from the inlet end plate, as shown in ②.	
2	Place the grounding bracket of cable shield on the chassis, and fasten the bracket with three M4 x 12 SEMS screws at the three positions shown in ③.	

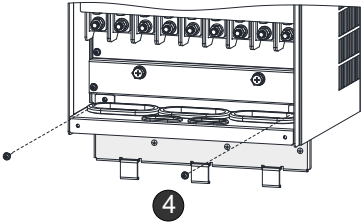
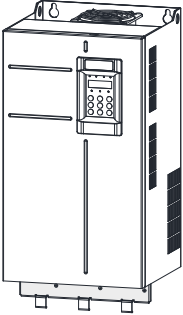
Step	Description	Diagram
3	Tighten two M4 x 12 SEMS screws onto the two positions shown in ④.	
4	Mount the cover.	

Wiring

Use shielded cables for motor output. Use a grounding bracket to achieve all-round connection with the shield, and crimp the lead wire of the shield to the PE terminal. The grounding bracket of cable shield is provided with a wire ferrule slot. Cover the exposed shield with insulation tape above the wire ferrule. The following figure shows the wiring.

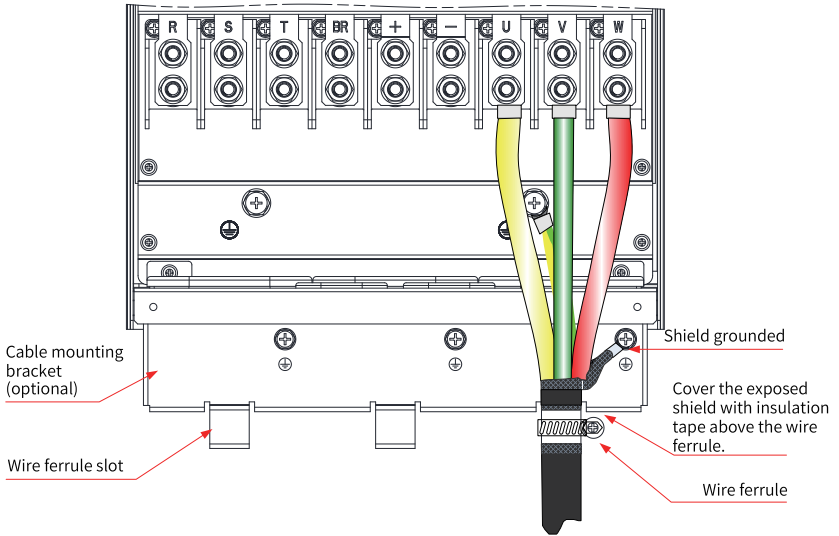

Figure 4-12 Cable shield wiring

4.8 Installing the Conduit Box

Context

- Models requiring UL Type 1 enclosure have a conduit box.
- The conduit box is optional and can be purchased as needed (applicable to T6 models and below). For T5 to T6 models, follow the following steps to install a conduit box.

Procedure

1. Lift the upper cover of the AC drive (as shown in Figure ①) to remove it, and then remove the wire slot plate (as shown in Figure ②).

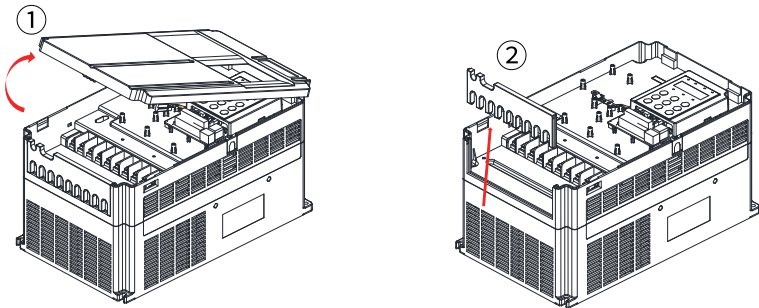

2. Remove the five M4 x 10 SEMS screws from the conduit box.

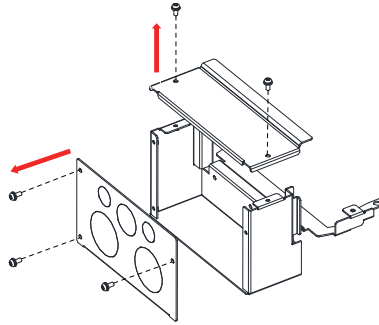

3. Remove the two screws in position ①.

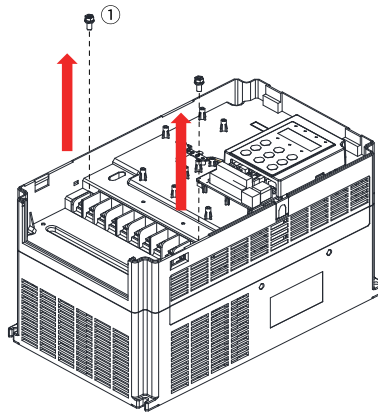

4. Snap the conduit box into the AC drive from top to bottom (as shown in Figure ①), tighten the two screws in position ②, and tighten the two M4 x 8 self-tapping screws in position ③.

Note

- The screws in Figure ② are the screws that have been removed at ① in Step 3.
 - The number of the screws to be fastened in Figure ③ varies with models. Two screws are required for T5 models, and four screws are required for T6 models. The screws are delivered with the conduit box and are to be fastened in the same way.
-

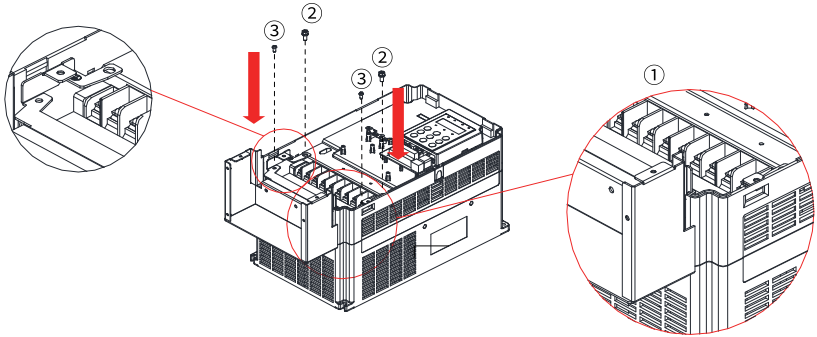

5. Knock off the threaded hole cover on the wire slot plate and install cables and bellows joints.

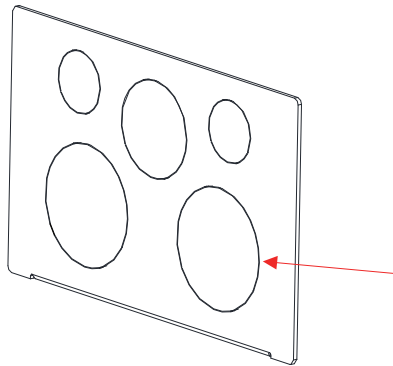

6. Use three M4 x 10 SEMS screws to mount the wire slot plate to the conduit box.

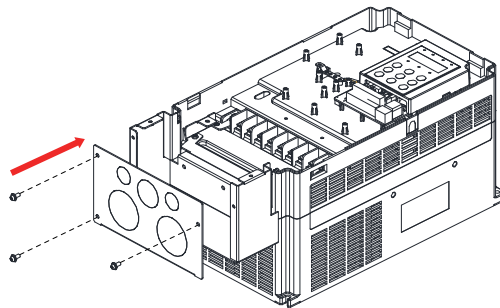

7. Mount the upper cover of the AC drive.

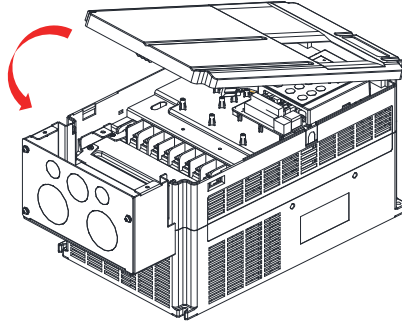

8. Use two M4 x 10 SEMS screws to mount the upper cover of the wire slot plate to the conduit box.

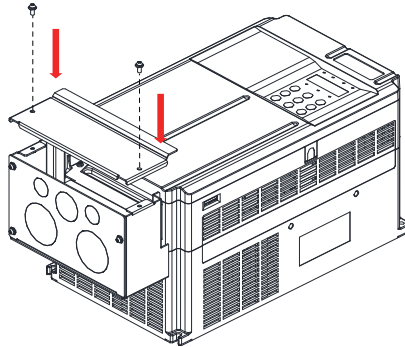

5 Mechanical Installation (T10 to T12 Models)

5.1 Installation Method

T10 to T12 models can be installed in a cabinet.

5.2 Installation Precautions

- Before installation, install the bottom mounting bracket in and mount the guide rails to the cabinet and provide the fixing beam for fixing the AC drive, with mounting holes reserved in the fixing beam. Reserve the clearance in the cabinet for connecting the copper busbar of the AC drive.
- The guide rails and the four casters at the bottom of the AC drive cooperate to help it come in or out of the cabinet. Align the casters with the guide rails before a push or pull. To ensure safety, ensure two persons are there cooperating to pull or push the AC drive.
- Reserve sufficient clearance for heat dissipation, including the heat dissipation of other equipment in the cabinet.
- Ensure two persons are there cooperating to push the AC drive into or pull it out of the cabinet. After the AC drive is in the cabinet, remove the cardboard from its air outlet to avoid over-temperature caused by failure to exhaust hot air inside.
- When installing the AC drive in the cabinet, install an insulation barrier at the top of the cabinet to prevent the exhaust air from circulating in the cabinet. Make sure air intake vents are provided in the lower part of the cabinet door.
- The cabinet is 2200 mm x 800 mm x 600 mm in size (including a ventilation top cover 200 mm in height). To ensure installation of the cabinet, reserve extra space for a cabinet base 100 mm in height.
- When the AC drive is installed in an enclosed environment, such as a cabinet or casing box, use a cooling fan or air conditioner to keep the temperature of the air taken in below 50°C. Failure to comply may result in overheating or fire.
- Cover the top of the AC drive with cloth or paper during installation to prevent metal shavings, oil, and water from entering during drilling. Foreign objects entering may cause malfunction of the AC drive. Remove the cloth or paper after the installation is completed. Failure to comply may degrade ventilation and result in unexpected heat.
- Use a mounting bracket that is flame retardant, where appropriate.
- For environments with metal dust, use a cabinet that can completely enclose the AC drive to isolate the AC drive from metal dust. In this case, as much space as possible should be provided in the fully sealed cabinet, and it is recommended that the radiator be installed outside the cabinet.
- Tighten all screws using the specified torque. Failure to comply may result in electric shock or fire.

- Keep combustible and explosive materials away from the AC drive.

5.3 Heat Dissipation Design

Consider the space for heat dissipation for installation of T9 to T12 models in a cabinet. A self-ventilated cabinet has no fan on the top.

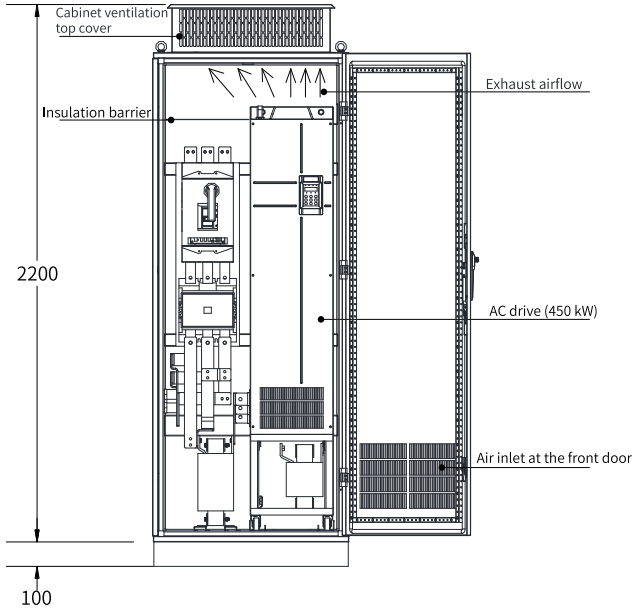

Figure 5-1 Self-ventilated cabinet

Table 5-1 Specifications of a self-ventilated cabinet

AC Drive Model	Quantity of Fans	Total Airflow (CFM)	Effective Area of the Cabinet Air Inlet (mm ²)	Effective Area of the Cabinet Air Outlet (mm ²)
T9 (132 kW)	2	541	31809	50894
T9 (160 kW)	2	620	31809	50894
T10 (200 kW)	2	586	31809	50894
T10 (220 kW)	2	722	31809	50894
T11 (250 kW)	3	789	47713	76341
T11 (280 kW)	3	882	47713	76341
T12 (315 kW)	3	644	47713	76341
T12 (355 kW)	3	796	47713	76341

AC Drive Model	Quantity of Fans	Total Airflow (CFM)	Effective Area of the Cabinet Air Inlet (mm ²)	Effective Area of the Cabinet Air Outlet (mm ²)
T12 (400 kW)	3	796	47713	76341
T12 (450 kW)	3	796	47713	76341

Note:

- CFM = 0.0283 m³/min
- "Actual Effective Area" indicates through-hole area.

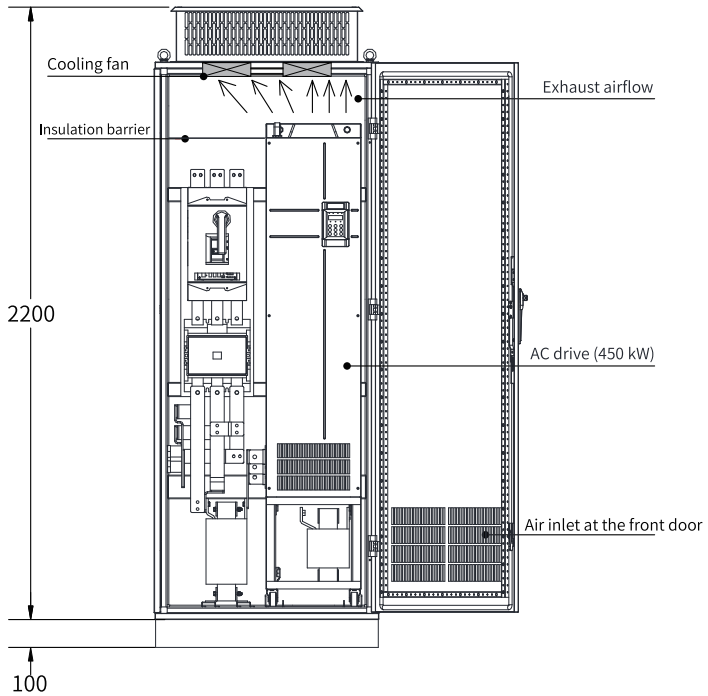

Figure 5-2 Forced ventilated cabinet (with fans on the top of the cabinet)

Table 5-2 Specifications of a forced ventilated cabinet

AC Drive Model	Quantity of Fans	Total Airflow (CFM)	Effective Area of the Cabinet Air Inlet (mm ²)	Max. Airflow Required by the Fans (CFM)	Effective Area of the Cabinet Air Outlet (mm ²)
T9 (132 kW)	2	541	31809	649	$S = 0.942 \times N \times (D_{out}^2 - D_{HUB}^2)$ where, N indicates the quantity of fans on the top, D _{out} indicates the fan diameter, and D _{HUB} indicates the diameter of the fan hub.
T9 (160 kW)	2	620	31809	744	
T10 (200 kW)	2	586	31809	703	
T10 (220 kW)	2	722	31809	866	
T11 (250 kW)	3	789	47713	947	
T11 (280 kW)	3	882	47713	1058	
T12 (315 kW)	3	644	47713	773	
T12 (355 kW)	3	796	47713	955	
T12 (400 kW)	3	796	47713	955	
T12 (450 kW)	3	796	47713	955	

Note:

- CFM = 0.0283 m³/min
- "Actual Effective Area" indicates through-hole area.

As shown in the following figure, an insulation barrier is required to prevent hot air exhausted from the AC drive circulating inside the cabinet.

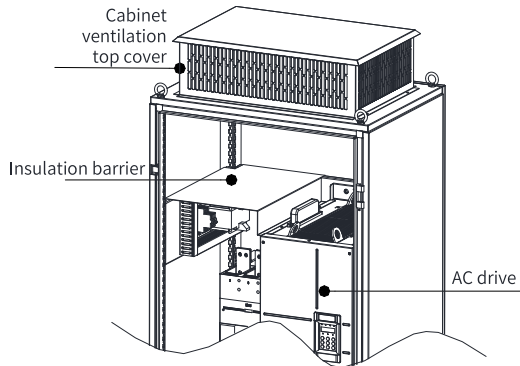

Figure 5-3 Insulation barrier in the cabinet

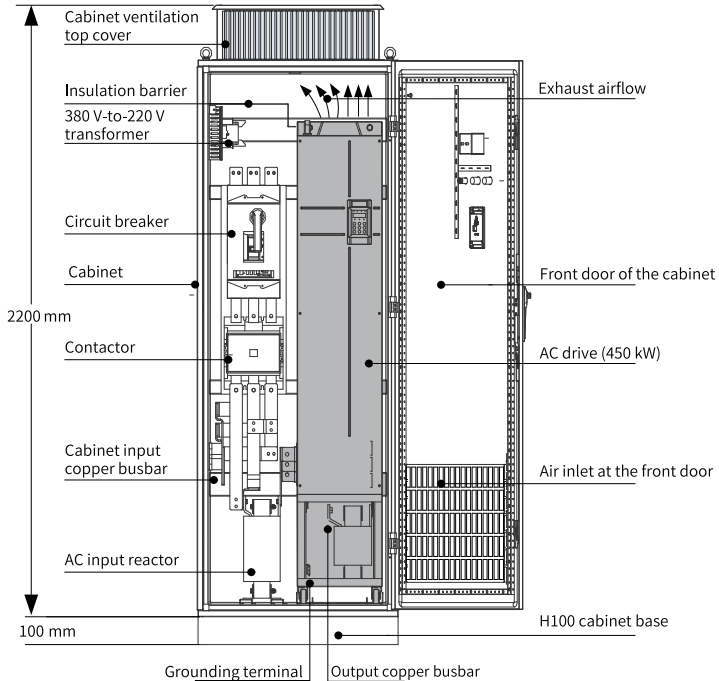

Figure 5-4 Recommended cabinet layout for T12 models

5.4 Installation in a Cabinet

Procedure

1. Install the fixing beam for fixing the AC drive in a nine-fold profile cabinet (PS cabinet), with mounting holes reserved in the beam.

"Figure 5-5 " on page 94 shows the cross section of the nine-fold profile.

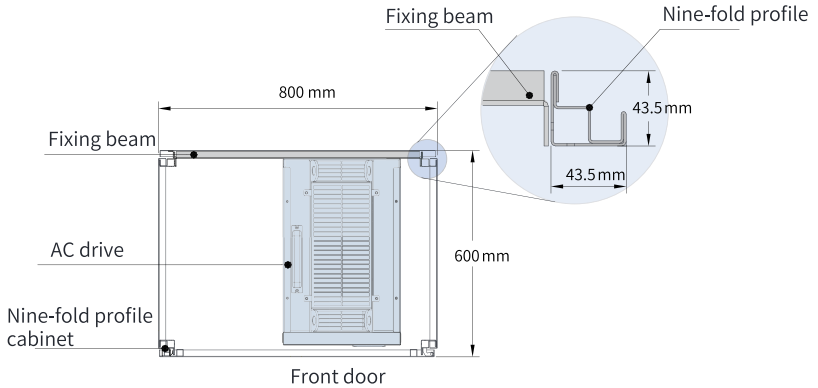

Figure 5-5 Top view of a cabinet for T11 and T12 models

To place the T11 or T12 model in a nine-fold profile cabinet 600 mm in depth, fold the back mounting plate inward, as shown in ["Figure 5-6" on page 94](#), to borrow the space of the column, which does not apply to the installation in a standard cabinet greater than 800 mm in depth. A 600 mm deep cabinet with both front access and back access is unable to house a T11 or T12 model. In this case, a standard cabinet with a depth of 800 mm is recommended.

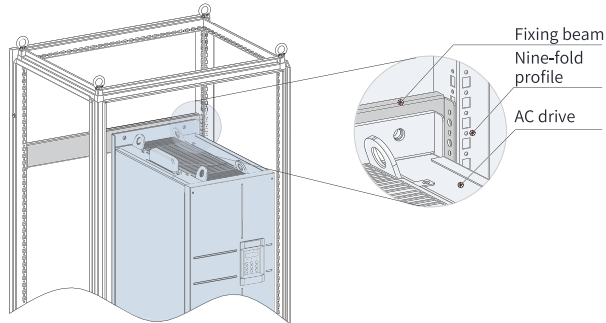

Figure 5-6 Perspective view of a cabinet for T11 and T12 models

2. Fix the bottom mounting bracket in a nine-fold profile cabinet.

Use six M5 self-tapping screws to fix the mounting bracket onto the rack base of the nine-fold profile cabinet, as shown in ["Figure 5-7" on page 95](#).

Drill holes for the mounting bracket and assemble the bracket on site if the cabinet is not a nine-fold profile one.

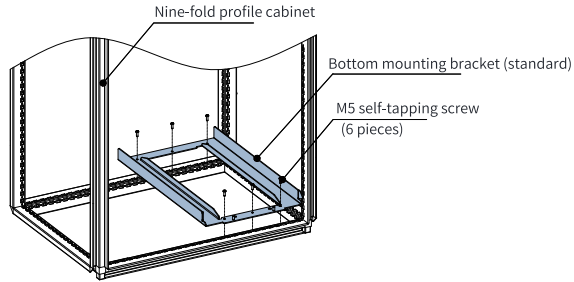

Figure 5-7 Installing the bottom mounting bracket

3. Make a guide rail assembly (model: MD500-AZJ-A3T10) and mount the guide rail assembly to the cabinet.

a. "Figure 5-8 " on page 95 shows how to make a guide rail assembly.

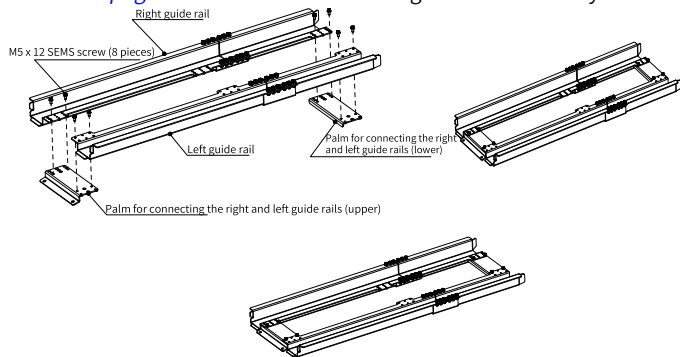

Figure 5-8 Making a guide rail assembly

b. Align the two round holes on the front end of the guide rail assembly with the screws of the mounting bracket, and lock them with two M6 nuts to mount the guide rail assembly to the cabinet, as shown in "Figure 5-9 " on page 96 .

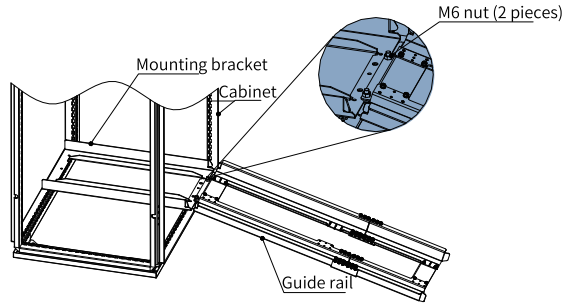

Figure 5-9 Mounting the guide rail assembly to the cabinet

4. Remove the cover from the AC drive.
For details about how to remove the cover, see "Removing Cover". With the cover removed, the auxiliary handle on the AC drive is exposed.
5. Align the casters of the AC drive with the guide rails and gently push the AC drive into the cabinet.
Use an auxiliary strap to prevent the AC drive from toppling when it is being pushed in or pulled out. It is recommended that two persons cooperate to complete this job.

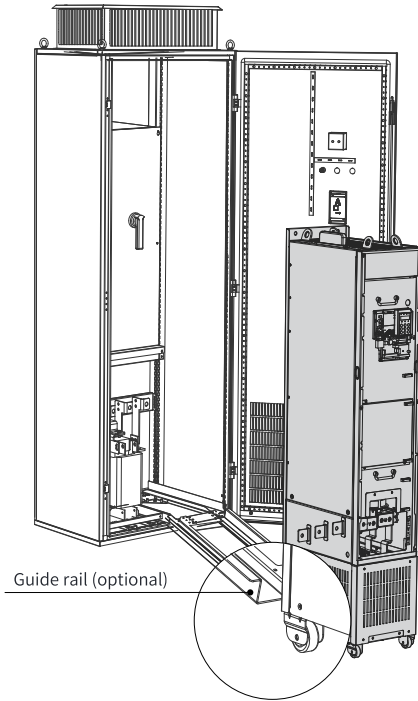

Figure 5-10 Aligning the casters with the guide rails

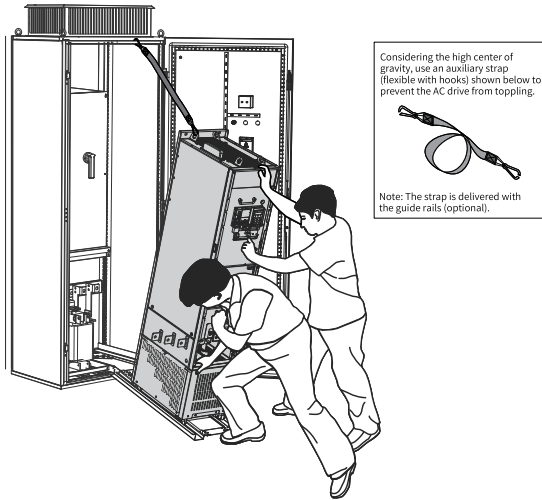

Figure 5-11 Pushing the AC drive into the cabinet

6. Remove the auxiliary strap, and drive screws into the four mounting holes in the back of the AC drive to fasten the AC drive to the fixing beam in the cabinet.

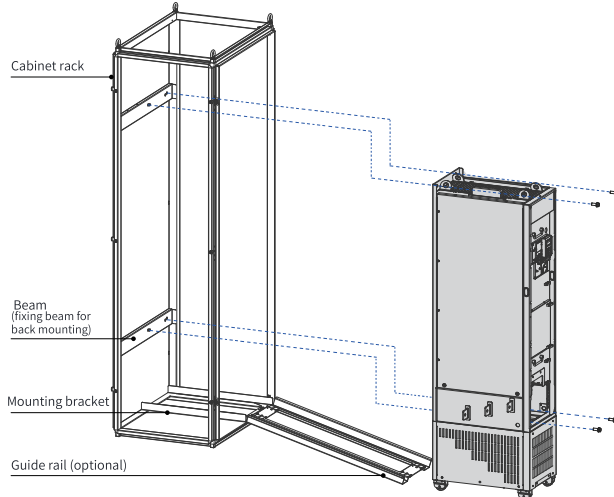

Figure 5-12 Fastening the AC drive to the fixing beam

7. Verify that the AC drive is securely installed, and remove the guide rails.
8. Remove the air filter baffle from the top of the AC drive. The baffle is used to prevent foreign objects such as screws from falling into the air filter when the AC drive is being installed in the cabinet.

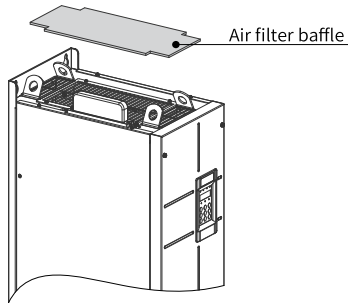

Figure 5-13 Removing the air filter baffle

5.5 Removing and Installing the Cover

5.5.1 Removing the Cover

When wiring the control circuit, remove the cover from the AC drive before proceeding with any jumper operation or connecting any PG card or extension card. When removing the cover, hold the cover with your hands and carefully lift the lower part of the cover to prevent the cover from falling off. Failure to comply may result in equipment damage or human injury.

Prerequisites

Before removing the cover, ensure that the AC drive has been powered off for longer than 10 minutes.

Procedure

1. Use a screwdriver to unscrew the six fixing screws of the cover.

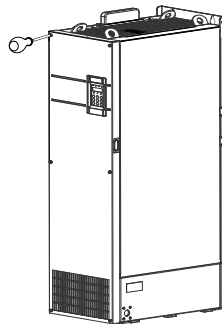

2. Hold the cover with your hands, and lift it in the arrow direction to remove it.

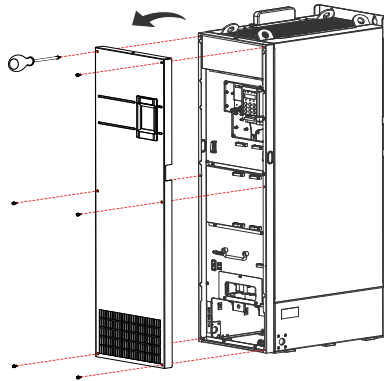

5.5.2 Installing the Cover

Remove the cover before wiring the main circuit and control circuit. After the wiring is completed, install the cover back.

Procedure

1. Hold the cover with your hands, align its upper edge with the upper edge snap on the chassis, and snap them together, with the snap-fit joint in the position shown in the following figure. Then align the six screw mounting holes in the cover with the cover mounting holes in the chassis and press them tightly against each other.

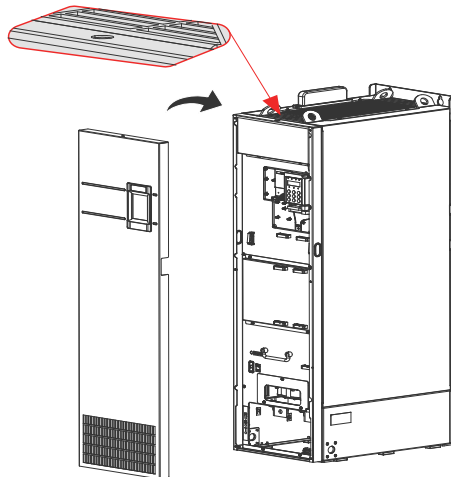

2. Drive six fixing screws into the holes with a screwdriver to fasten the cover.

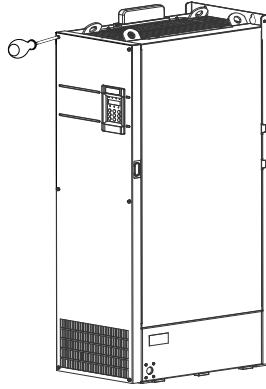

6 Mechanical Installation (T13 Models)

6.1 Installation Method

T13 models are cabinet-type AC drives that should be vertically mounted on the floor. Multiple cabinets can be installed in parallel.

6.2 Installation Precautions

- Reserve sufficient clearance for heat dissipation, including the heat dissipation of other devices around the AC drive.
- Cover the top of the AC drive with cloth or paper during installation to prevent metal shavings, oil, and water from entering during drilling. Foreign objects entering may cause malfunction of the AC drive. Remove the cloth or paper after the installation is completed. Failure to comply may degrade ventilation and result in unexpected heat.
- Tighten all screws using the specified torque. Failure to comply may result in electric shock or fire.
- Keep combustible and explosive materials away from the AC drive.

6.3 Requirements on Ground Flatness

1. Place the AC drive on a flat and sturdy mounting base able to bear the weight of the AC drive
2. Ensure the normal use of the door lock when opening and closing the cabinet door.
3. When installing cabinets in parallel, ensure that there is no gap between the cabinets and the floor. For any inevitable gap (as shown by ① in the following figure), use a pad (as shown by ② in the following figure) to level the cabinet, and use proper fillings (for example, fireproof mud) to fill the gap.

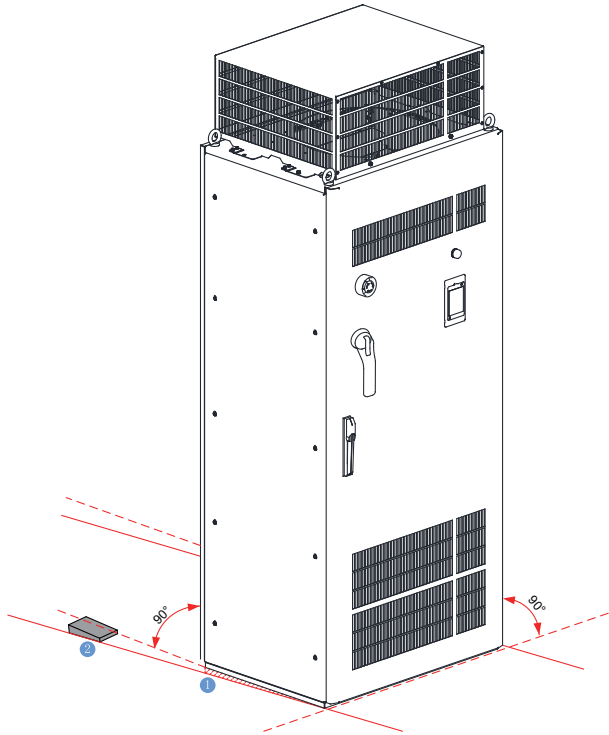

Figure 6-1 Requirements on mounting floor

6.4 Installing Expansion Screws

To install the cabinet on a cement floor, embed expansion nuts in advance in the floor at positions corresponding to the fixing holes of the cabinet for fixing the AC drive.

The following figure shows the steps of installing expansion screws, where ① indicates an expansion screw, ② indicates the cabinet, and ③ indicates an M12 bolt.

1. Drill a hole for the expansion screw. The hole diameter shall be slightly smaller than the maximum outer diameter of the screw, and the hole depth shall be greater than the expansion screw length. The expansion screw must be vertical to the ground, as shown by "Step 1" in the following figure.
2. The expansion screw consists of a bolt spring enclosure and a screw part. Use a hammer to knock the expansion screw into the hole and ensure that the screw head is below the ground surface, as shown by "Step 2" in the following figure.
3. Place the cabinet and tighten the M12 screw. The screw part of the expansion screw will be pulled upward, so that the spring enclosure will be deformed outward for fixing, as shown by "Step 3" in the following figure.

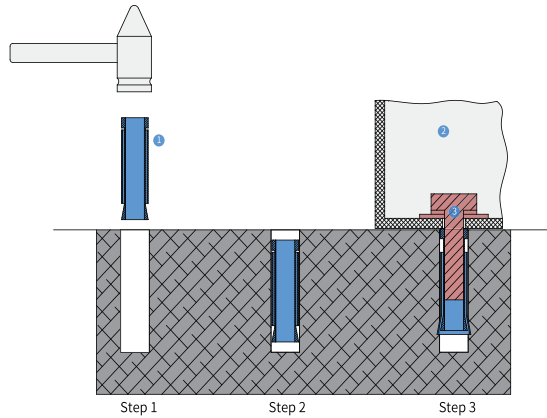

Figure 6-2 Installing an expansion screw

6.5 Requirements on Foundation

1. Separate high-voltage cables from low-voltage cables by placing them on different brackets. For failure to do so due to any restrictions, place the low-voltage cables in a completely enclosed metal pipe.
2. Ensure that the cable trench is non-flammable, smooth, and well protected from moisture, dust, and animals.
3. During foundation design, take the following factors into consideration: access space in front of the cabinet, and wiring of power cables, actuating motor cables, and system control cables. The cabinet comes with a cable trench or cable guide. Separate power cables from signal cables. Failure to comply may affect the operation of the AC drive. The following figure shows the routing and related requirements.

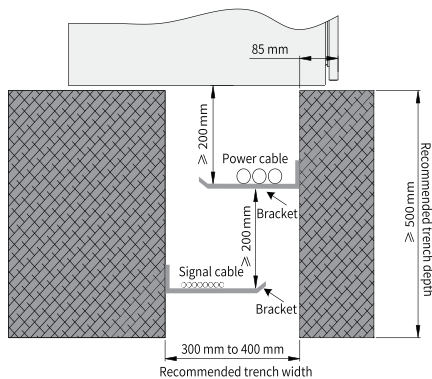
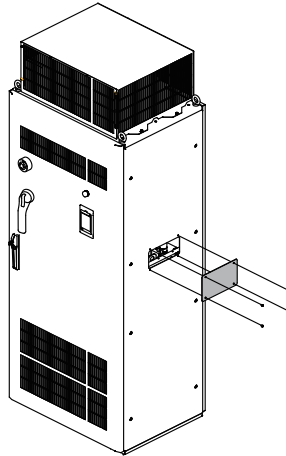

Figure 6-3 Foundation layout

6.6 Installing an External Braking Unit

Procedure

1. Remove the lateral closure plate of the AC cabinet.



2. Open the cabinet door and mount the adapter busbar for the external braking unit, as shown in the following figure.

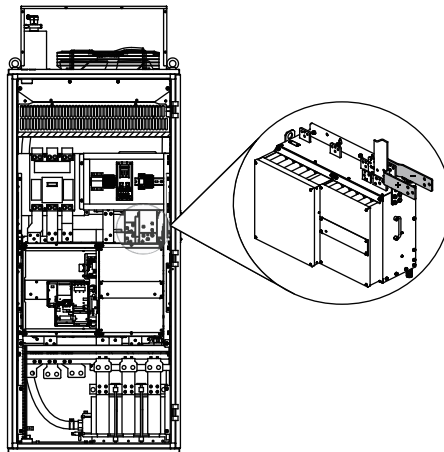

3. Connect the AC drive to the external braking unit.

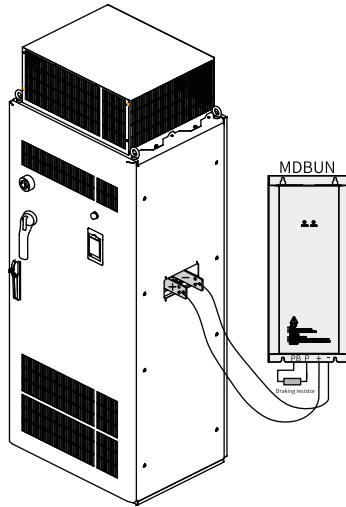

Figure 6-4 Connecting the AC drive to the external braking unit

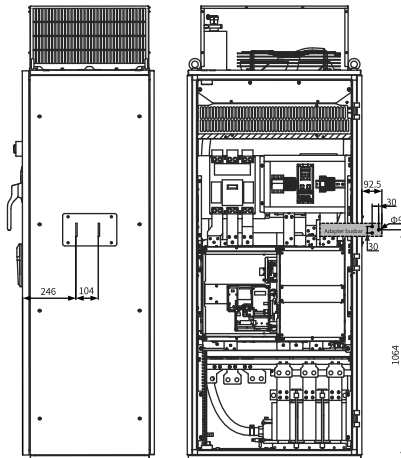

Figure 6-5 Dimensions of the position for installing the adapter busbar (unit: mm)

6.7 Checklist of Mechanical Installation

Fill in the "Checked" column with a tick once the action is done.

Table 6-1 Checklist of Mechanical Installation

Item	Action	Compliant	Checked
1	Check the anti-inclination label.		
2	Check that the packing box is intact and free of damage and damp.		
3	Check that the load-bearing capacity of the floor and the environment meet the installation requirements. For details, see "6.3 Requirements on Ground Flatness" on page 102 and "1.2.1 Environment" on page 16 .		
4	Check that the ceiling height meets the minimum requirements (smooth ventilation). Ensure sufficient space for unobstructed air supply and exhaust. Reserve sufficient space for safe passing with the cabinet door open. For details, see "1.2.2 Clearances" on page 17 .		
5	Upon unpacking, check that the cabinet enclosure is free of deformation, paint peeling off, and cracking, and that there is no water stain in the cabinet.		
6	Check that the accessories (user guide and options) in the cabinet are complete.		
7	Remove the wooden pallet before placing the cabinet at the final installation site. For details, see "3.4 Unpacking" on page 57 .		
8	Firmly attach the cabinet to the fixing points provided.		
9	Install all contact protective devices (protection plates) inside and outside the cabinet before commissioning.		

7 Electrical Installation

7.1 Electrical Wiring Diagram

The typical wiring diagram is shown in "Figure 7-1" on page 108 .

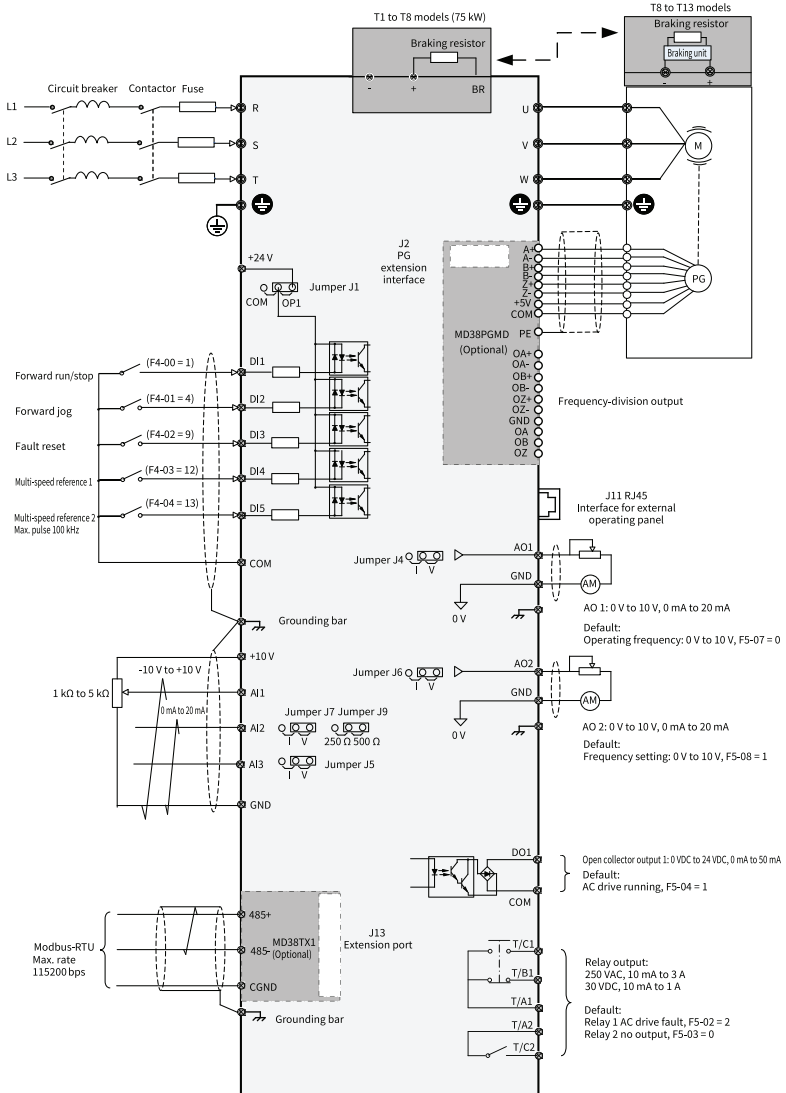

Figure 7-1 Standard wiring

Note

For T1 to T8 (75 W) models (model number containing letter B) and T8 to T13 models (model number without letter B), the connection indicated by the double-headed arrow is different.

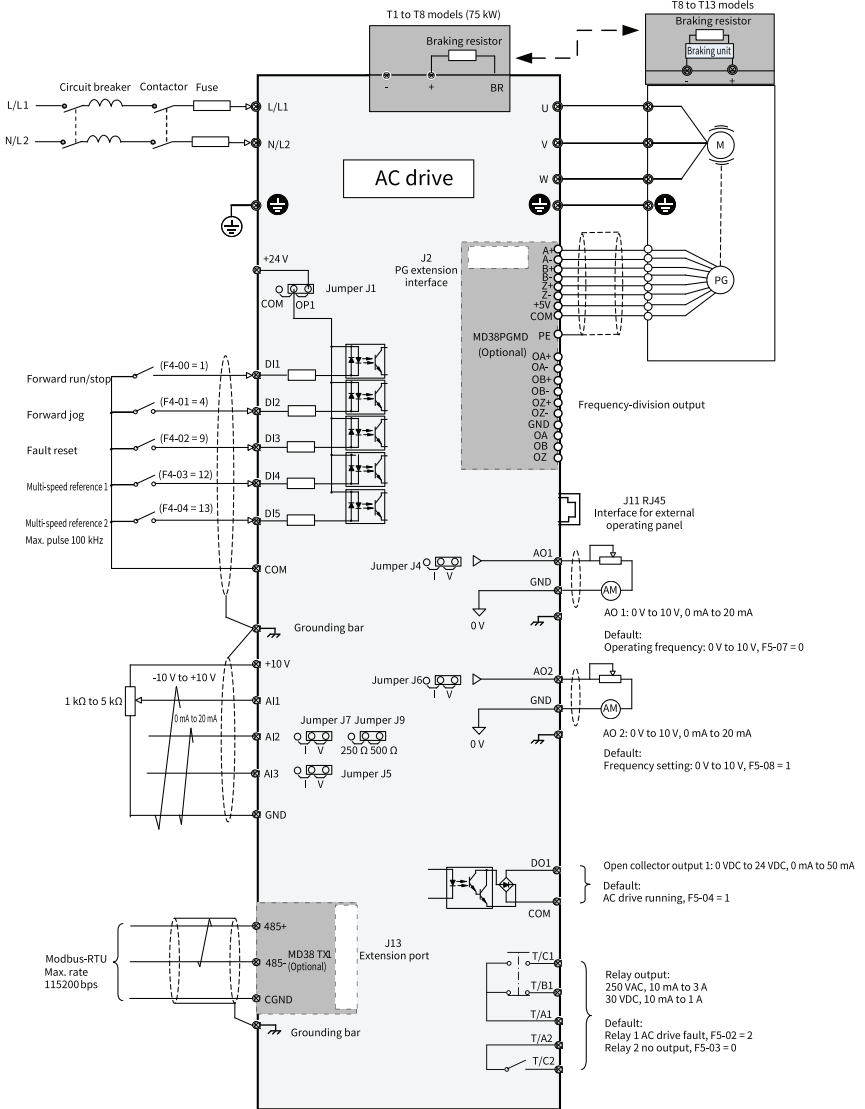

Figure 7-2 Standard wiring (single-phase 220 V)

T13 models

"Figure 7-1" on page 108 shows the standard wiring of the cabinet, and "Figure 7-3" on page 111 shows the electrical connection in the cabinet.

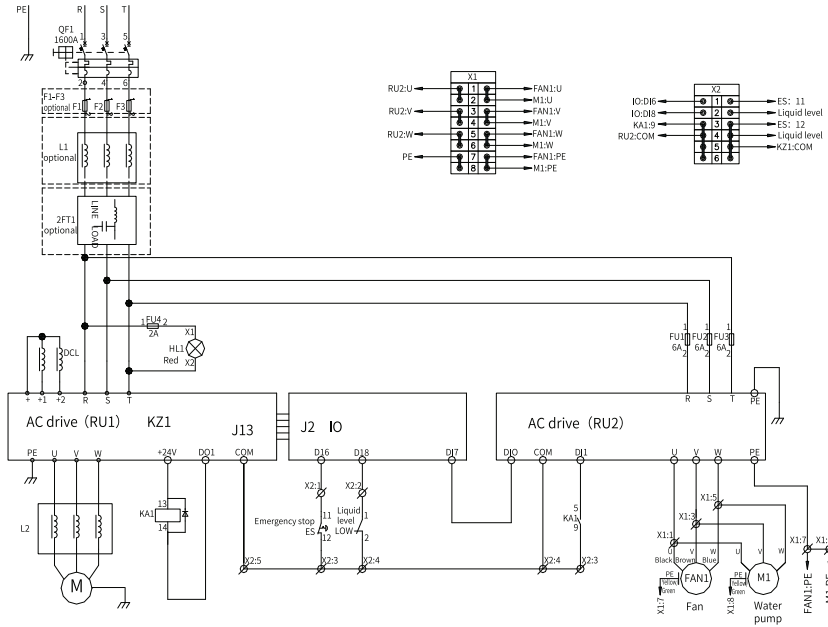

Figure 7-3 Electrical connection in the cabinet (T13 models)

7.2 Inspection Before Wiring

T1 to T12 models

- Avoid any wiring while the power is live, and keep all circuit breakers OFF in the process. Failure to comply may result in an electric shock.
- Start wiring at least 10 minutes after the input and output are turned off when the power indicators are completely off.
- Ensure that the motors, cabinets, and other components are installed and connected in accordance with the recognized technical rules in the country of installation and with other applicable regional regulations. Pay special attention to regulations on cable dimensions, fuses, grounding, open circuits, isolation, and overcurrent protection.
- When a branch fuse trips, the faulty current may have been cut off. To reduce the risk of fire and electric shocks, check the conductive parts and other components and replace the damaged ones. Find the cause of the tripping fuse and make sure the problem is solved.

T13 models

- The cabinet-housed AC drive operates under high voltage. Do not attempt to connect any wires while the voltage is live.

- Only allow qualified professionals to do the job.
- Exercise caution even when the AC drive is turned off, as there may still be external supply voltage. The main circuit and control circuit terminals may still be live even when the motor is stopped.
- Start wiring at least 15 minutes after the input and output are turned off when the power indicators are completely off.
- Ensure that the motors, cabinets, and other components are installed and connected in accordance with the recognized technical rules in the country of installation and with other applicable regional regulations. Pay special attention to regulations on cable dimensions, fuses, grounding, open circuits, isolation, and overcurrent protection.
- When a branch fuse trips, the faulty current may have been cut off. To reduce the risk of fire and electric shocks, check the conductive parts and other components of the cabinet and replace the damaged ones. Find the cause of the tripping fuse and make sure the problem is solved.

7.3 Main Circuit Connection

7.3.1 Main Circuit Terminals

T1 to T9 models

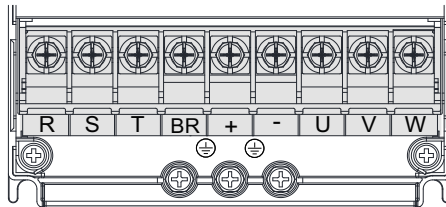

Figure 7-4 Arrangement of main circuit terminals of T1 to T4 models

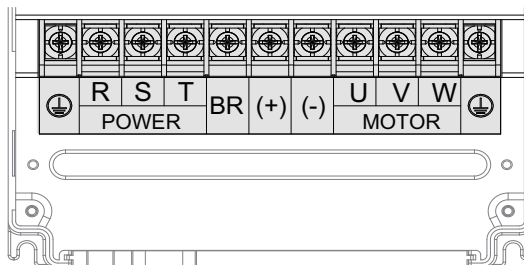

Figure 7-5 Arrangement of main circuit terminals of T5 to T8 models

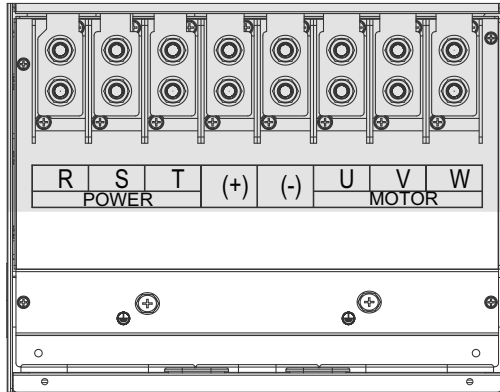



Figure 7-6 Arrangement of main circuit terminals of T9 models

Table 7-1 Main circuit terminals

Terminal	Name	Description
R, S, T	Three-phase power supply input terminals	Connected to AC input three-phase power supply.
(+), (-)	Positive and negative terminals of DC bus	Common DC busbar input point, connected to the external braking unit of T9 models and above.
(+), BR	Braking resistor connection terminals	Connected to the braking resistor of T8 models and below.
U, V, W	Output terminals	Connected to a three-phase motor.
	Grounding terminal (PE)	Used for protective grounding.

T10 to T12 models

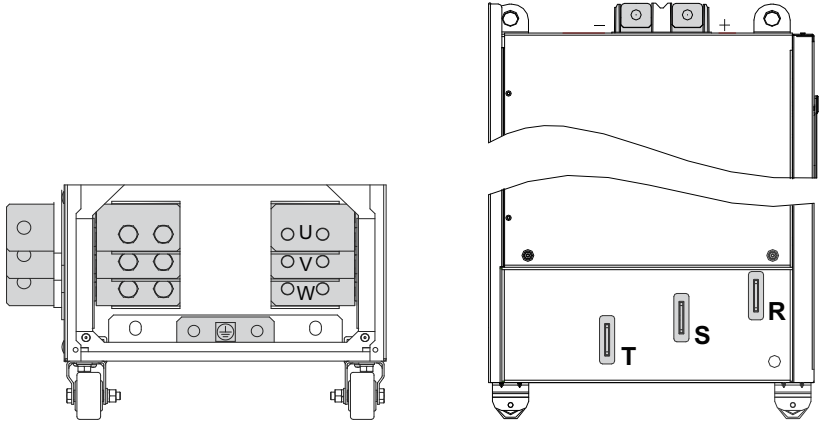



Figure 7-7 Arrangement of main circuit terminals of T10 to T12 models

Table 7-2 Main Circuit Terminals

Terminal	Name	Description
R, S, T	Three-phase power supply input terminals	Connected to AC input three-phase power supply.
+, -	Positive and negative terminals of DC bus	Common DC busbar input point, connected to an external braking unit.
U, V, W	AC drive output terminals	Connected to a three-phase motor.
	Grounding terminal (PE)	Used for protective grounding.

T13 models

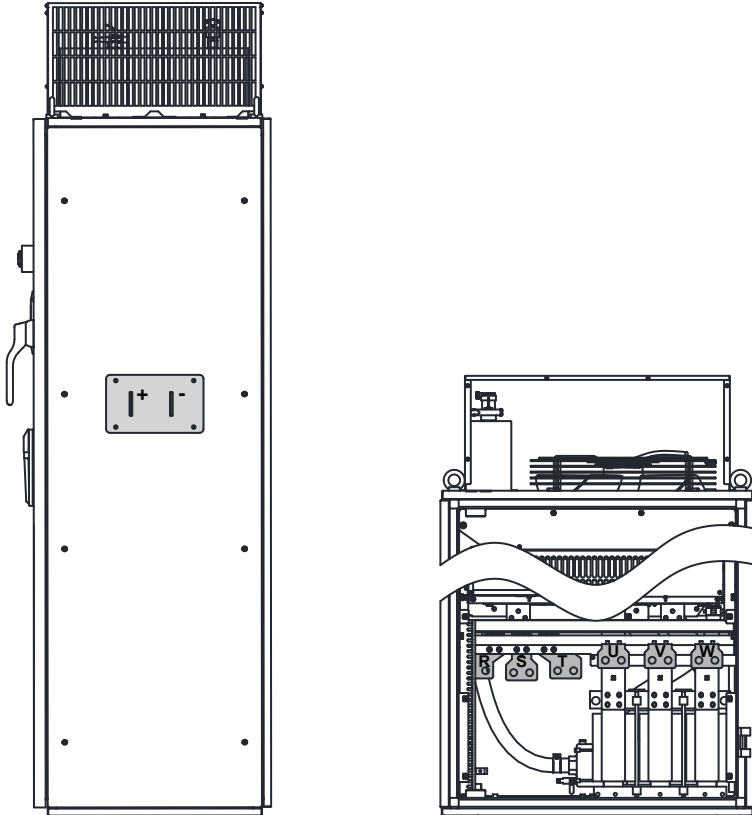



Figure 7-8 Arrangement of main circuit terminals of T13 models

Table 7-3 Main Circuit Terminals

Terminal	Name	Description
R, S, T	Three-phase power supply input terminals	Connected to AC input three-phase power supply.
+, -	Positive and negative terminals of DC bus	Common DC busbar input point, connected to an external braking unit.
U, V, W	AC drive output terminals	Connected to a three-phase motor.
	Grounding terminal (PE)	Used for protective grounding.

7.3.2 Main Circuit Terminal Dimensions and Cable Selection

T1 to T2

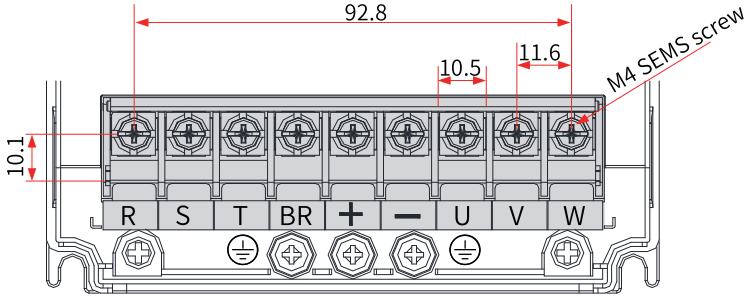

Figure 7-9 Main circuit terminal dimensions of T1 and T2 models

Table 7-4 Recommended specifications of main circuit cables for T1 and T2 models

Structure	Model	Rated Input Current A	RST/UWV		Grounding Wire		Screw	Tightening Torque N·m (lb·in.)
			Cable (mm ²) ^{<1>}	Cable Lug	Cable (m m ²) ^{<1>}	Cable Lug		
T1	MD500T0.4GB-PLUS	1.8	3 x 0.75	TNR0.75-4	0.75	TN R0.75-4	M4	1.2 (10.6)
	MD500T0.7GB-PLUS	2.4						
	MD500T1.1GB-PLUS	3.7						
	MD500T1.5GB-PLUS	4.6						
	MD500T2.2GB-PLUS	6.3						
	MD500T3.0GB-PLUS	9.0	3 x 1	TNR1.25-4	1	TN R1.25-4	M4	1.2 (10.6)
T2	MD500T3.7GB-PLUS	11.4	3 x 1.5	TNR1.25-4	1.5	TN R1.25-4	M4	1.2 (10.6)
	MD500T5.5GB-PLUS	16.7	3 x 2.5	TNR2-4	2.5	TNR2-4	M4	1.2 (10.6)

T3

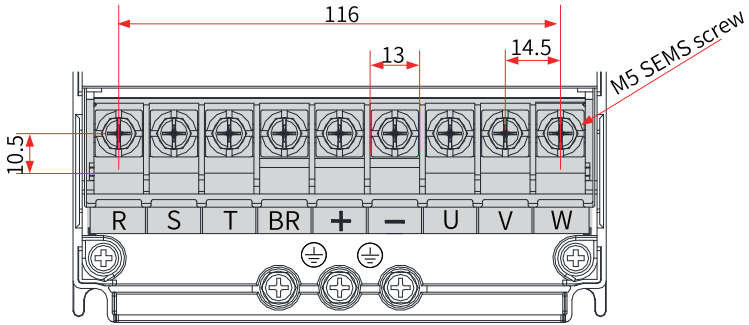

Figure 7-10 Main circuit terminal dimensions of T3 models

Table 7-5 Recommended main circuit cables for T3 models

Structure	Model	Rated Input Current A	RST/UWV		Grounding Wire		Screw	Tightening Torque N•m (lbf•in.)
			Cable (mm ²) ^{<1>}	Cable Lug	Cable (mm ²) ^{<1>}	Cable Lug		
T3	MD500T7.5GB-PLUS	21.9	3 x 4	TNR3.5-5	4	TNR3.5-5	M5	2.8 (24.8)
	MD500T11GB-PLUS	32.2	3 x 6	TNR5.5-5	6	TNR5.5-5	M5	2.8 (24.8)

T4

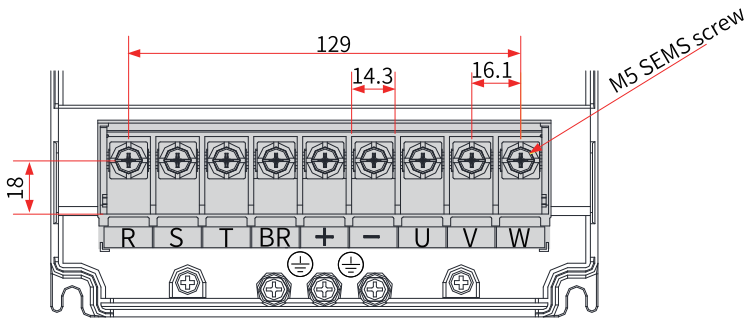

Figure 7-11 Main circuit terminal dimensions of T4 models

Table 7-6 Recommended main circuit cables for T4 models

Structure	Model	Rated Input Current A	RST/UWV		Grounding Wire		Screw	Tightening Torque N•m (lbf•in.)
			Cable (mm ²) ^{<1>}	Cable Lug	Cable (mm ²) ^{<1>}	Cable Lug		
T4	MD500T15GB-PLUS	41.3	3 x 10	TNR8-5	10	TNR8-5	M5	2.8 (24.8)

T5

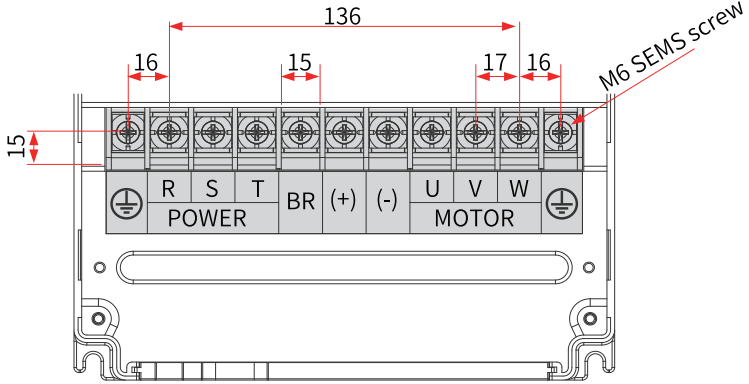

Figure 7-12 Main circuit terminal dimensions of T5 models

Table 7-7 Recommended main circuit cable selection for T5 models

Structure	Model	Rated Input Current A	RST/UWW		Grounding Wire		Screw	Tightening Torque N•m (lb•in.)
			Cable (mm ²) ^{<1>}	Cable Lug	Cable (mm ²) ^{<1>}	Cable Lug		
T5	MD500T18.5G(B)-PLUS MD500T18.5G(B)-T-PLUS	49.5	3 x 10	GTNR10-6	10	GTNR10-6	M6	4.8 (45.2)
	MD500T22G(B)-PLUS MD500T22G(B)-T-PLUS	59.0	3 x 16	GTNR16-6	16	GTNR16-6	M6	4.8 (45.2)

T6

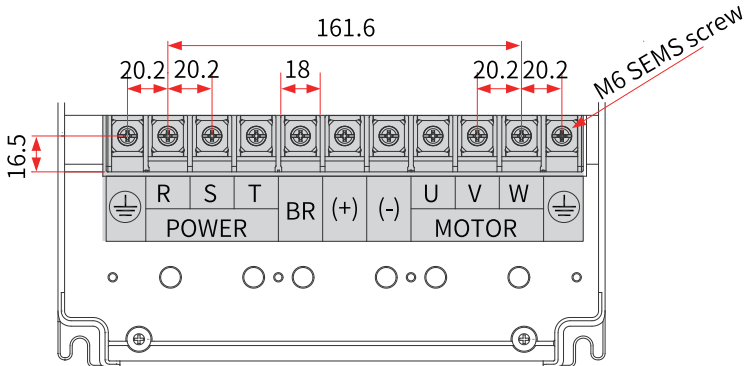

Figure 7-13 Main circuit terminal dimensions of T6 models

Table 7–8 Recommended main circuit cables for T6 models

Structure	Model	Rated Input Current A	RST/UVW		Grounding Wire		Screw	Tightening Torque N•m (lbf•in.)
			Cable (mm ²)<1>	Cable Lug	Cable (mm ²)<1>	Cable Lug		
T6	MD500T30G(B)-PLUS	57.0	3 x 16	GTNR16-6	16	GTNR16-6	M6	4.8 (45.2)
	MD500T37G(B)-PLUS	69.0	3 x 25	GTNR25-6	16	GTNR16-6	M6	4.8 (45.2)

T7

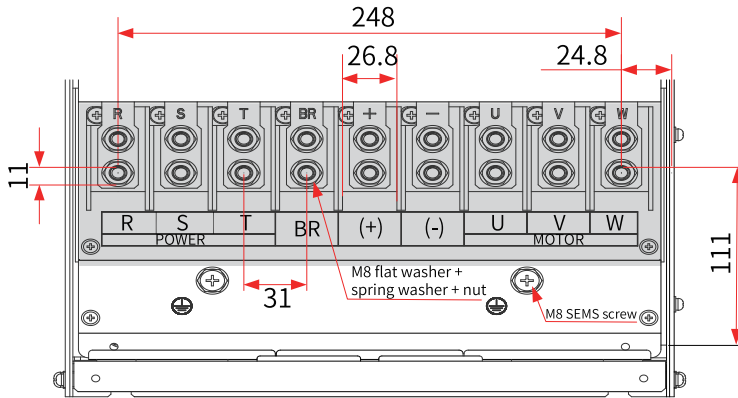

Figure 7-14 Main circuit terminal dimensions of T7 models

Table 7–9 Recommended main circuit cables for T7 models

Structure	Model	Rated Input Current A	RST/UVW		Grounding Wire		Screw	Tightening Torque N•m (lbf•in.)
			Cable (mm ²)<1>	Cable Lug	Cable (mm ²)<1>	Cable Lug		
T7	MD500T45G(B)-PLUS	89.0	3 x 35	GTNR35-8	16	GTNR16-8	M8	13.0 (115.2)
	MD500T55G(B)-PLUS	106.0	3 x 50	GTNR50-8	25	GTNR25-8	M8	13.0 (115.2)

T8

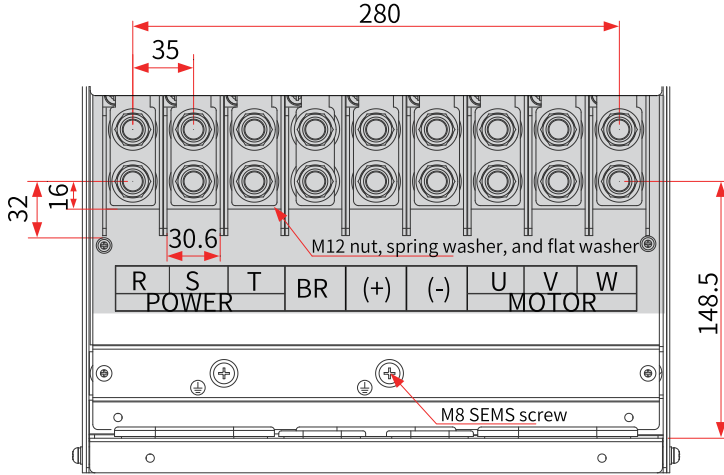

Figure 7-15 Main circuit terminal dimensions of T8 models

Table 7-10 Recommended main circuit cables for T8 models

Structure	Model	Rated Input Current A	RST/UVW		Grounding Wire		Screw	Tightening Torque N•m (lbf•in.)
			Cable (mm ²) ^{<1>}	Cable Lug	Cable (mm ²) ^{<1>}	Cable Lug		
T8	MD500T75G(B)-PLUS	139.0	3 x 70	GTNR70-12	35	GTNR35-12	M12	35.0 (310.1)
	MD500T90G-PLUS	164.0	3 x 95	GTNR95-12	50	GTNR50-12	M12	35.0 (310.1)
	MD500T110G-PLUS	196.0	3 x 120	GTNR120-12	70	GTNR70-12	M12	35.0 (310.1)

T9

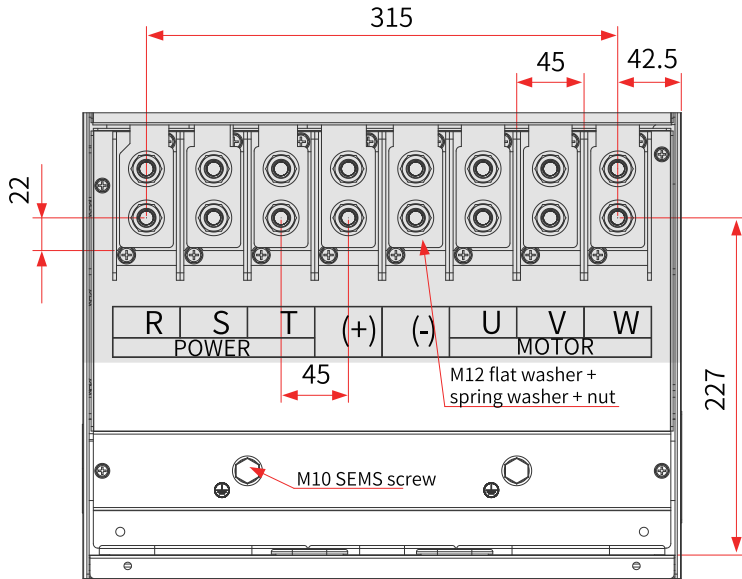

Figure 7-16 Main circuit terminal dimensions of T9 models

Table 7-11 Recommended main circuit cables for T9 models

Structure	Model	Rated Input Current A	RST/UVW		Grounding Wire		Screw	Tightening Torque N·m (lbf·in.)
			Cable (mm ²) ^{<1>}	Cable Lug	Cable (mm ²) ^{<1>}	Cable Lug		
T9	MD500T132G-PLUS	240.0	3 x 150	BC150-12	95	BC95-12	M12	35.0 (310.1)
	MD500T160G-PLUS	287.0	3 x 185	BC185-12	95	BC95-12	M12	35.0 (310.1)

T10

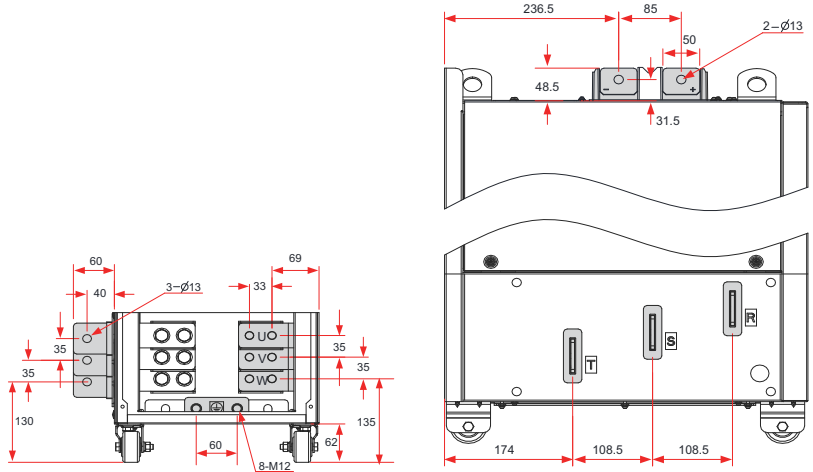

Figure 7-17 Main circuit terminal dimensions of T10 models (without output reactors)

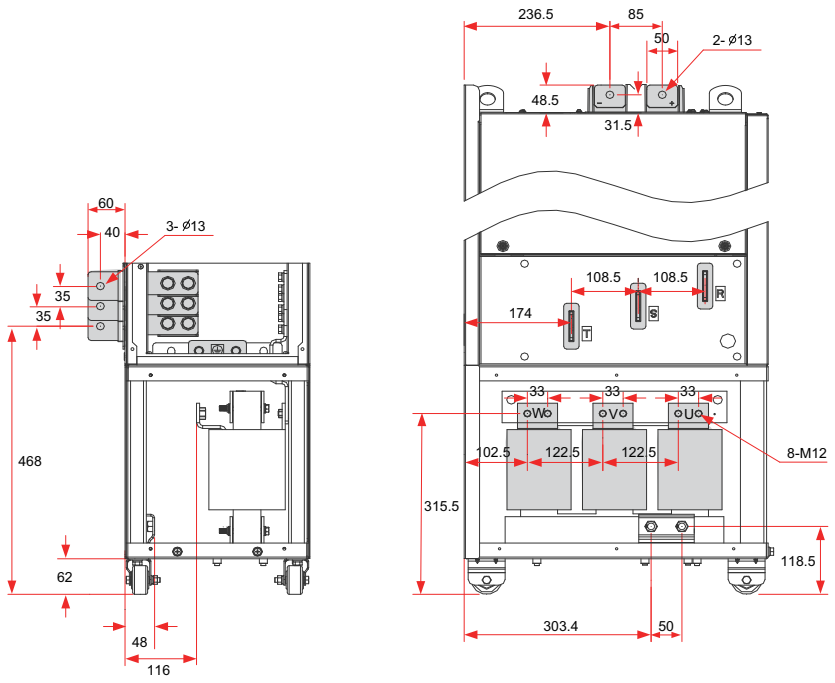

Figure 7-18 Main circuit terminal dimensions of T10 models (with output reactors)

The copper busbars in the preceding figures can be removed as required. The following figure shows the dimensions of the main circuit terminals without copper busbars.

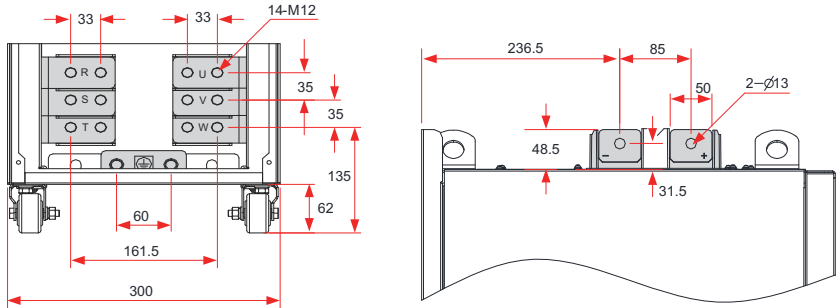

Figure 7-19 Main circuit terminal dimensions of T10 models (without copper busbars and output reactors)

Table 7-12 Recommended main circuit cables for T10 models

Structure	Model	Rated Input Current A	RST/UVW		Grounding Wire		Screw	Tightening Torque N•m (lbf•in.)
			Cable (mm ² <sup>1>)	Cable Lug	Cable (mm ² <sup>1>)	Cable Lug		
T10	MD500T200G-PLUS	365.0	2 x (3 x 95)	BC95-12	95	BC95-12	M12	35.0 (310.1)
	MD500T200G-L-PLUS							
	MD500T220G-PLUS	410.0	2 x (3 x 120)	BC120-12	120	BC120-12	M12	35.0 (310.1)
	MD500T220G-L-PLUS							

T11

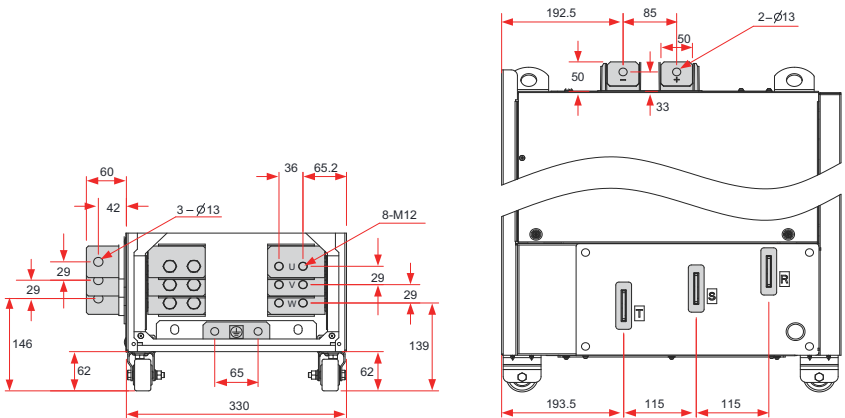

Figure 7-20 Main circuit terminal dimensions of T11 models (without output reactors)

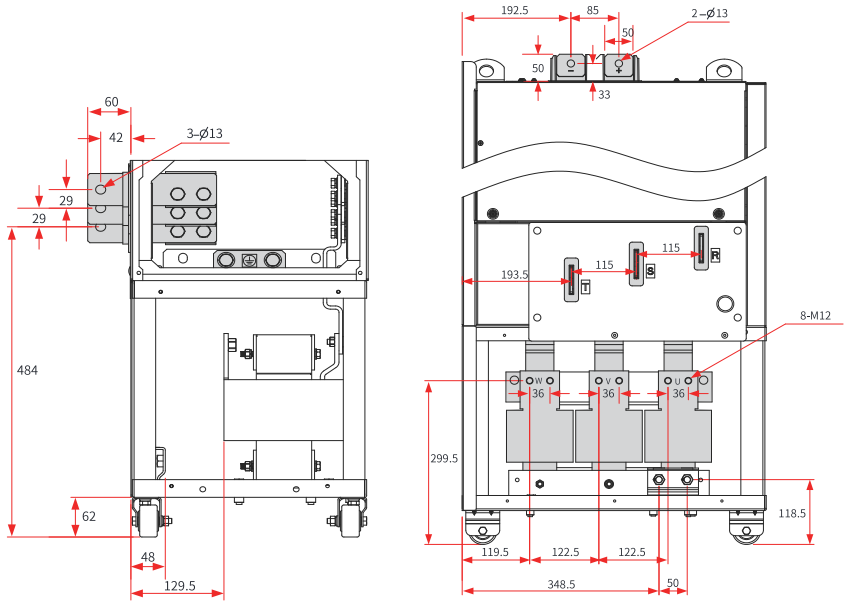

Figure 7-21 Main circuit terminal dimensions of T11 models (with output reactors)

The copper busbars in the preceding figures can be removed as required. The following figure shows the dimensions of the main circuit terminals without copper busbars.

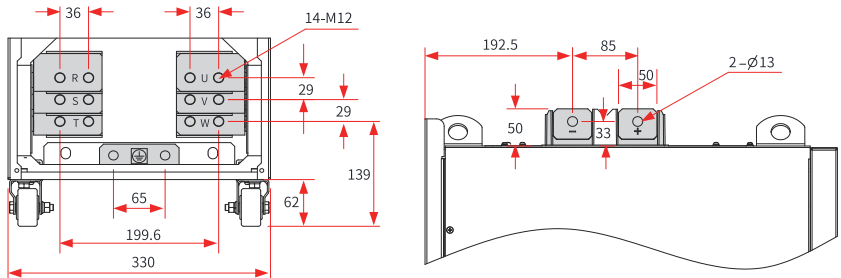

Figure 7-22 Main circuit terminal dimensions of T11 models (without copper busbars and output reactors)

Table 7-13 Recommended main circuit cables for T11 models

Structure	Model	Rated Input Current A	RST/UVW		Grounding Wire		Screw	Tightening Torque N·m (lbf·in.)
			Cable (mm ²) ^{<1>}	Cable Lug	Cable (mm ²) ^{<1>}	Cable Lug		
T11	MD500T250G-PLUS MD500T250G-L-PLUS	441.0	2 x (3 x 120)	BC120-12	120	BC120-12	M12	35.0 (310.1)
	MD500T280G-PLUS MD500T280G-L-PLUS	495.0	2 x (3 x 150)	BC150-12	150	BC150-12	M12	35.0 (310.1)

T12

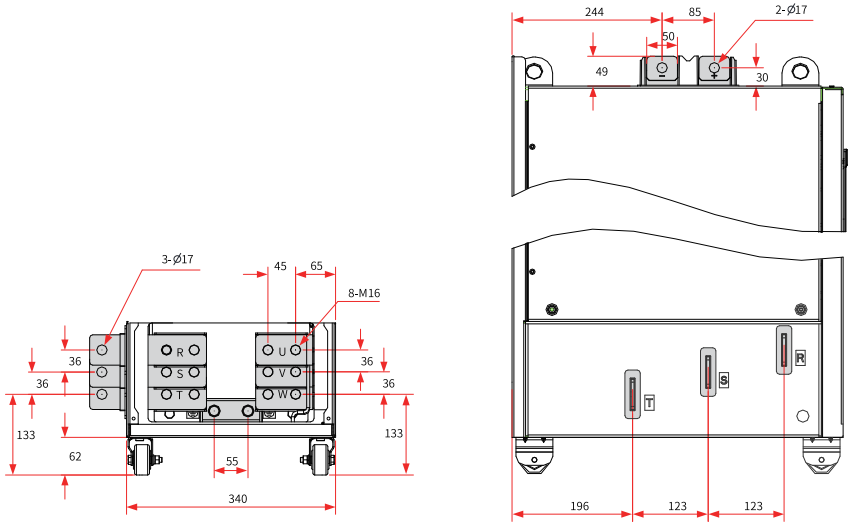

Figure 7-23 Main circuit terminal dimensions of T12 models (without output reactors)

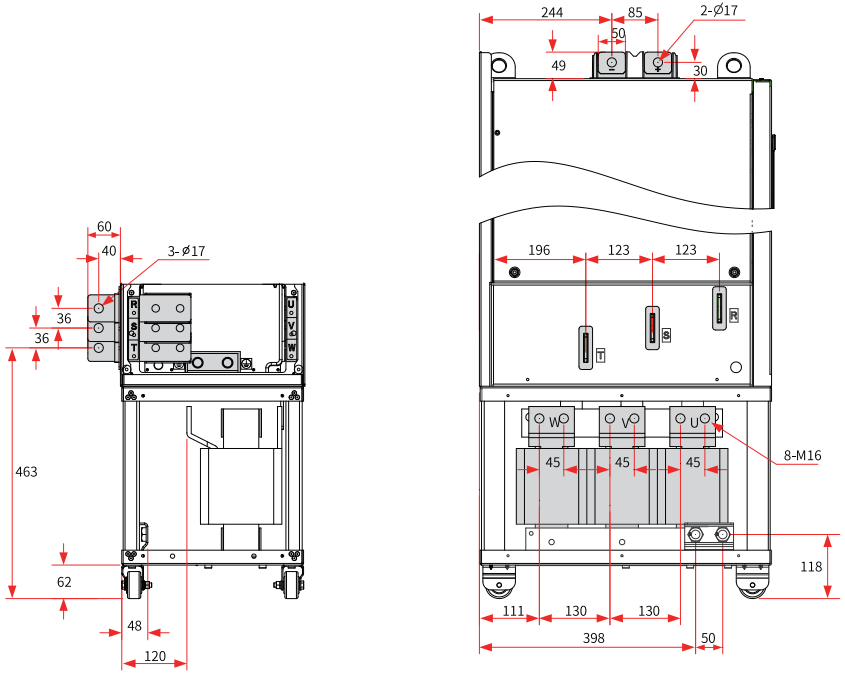

Figure 7-24 Main circuit terminal dimensions of T12 models (with output reactors)

The copper busbars in the preceding figures can be removed as required. The following figure shows the dimensions of the main circuit terminals without copper busbars.

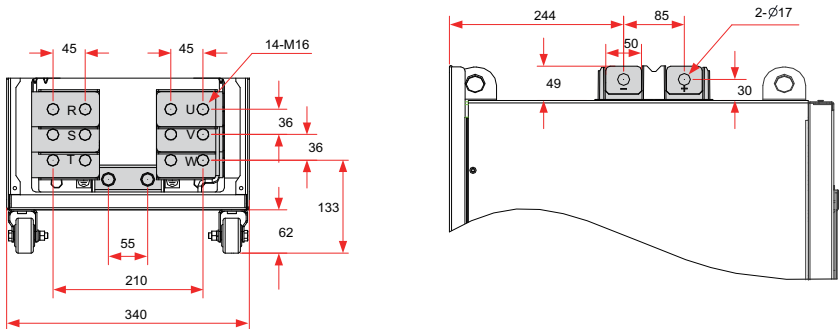

Figure 7-25 Main circuit terminal dimensions of T12 models (without copper busbars and output reactors)

Table 7-14 Recommended main circuit cables for T12 models

Structure	Model	Rated Input Current A	RST/UVW		Grounding Wire		Screw	Tightening Torque N•m (lbf•in.)
			Cable (mm ²)<1>	Cable Lug	Cable (mm ²)<1>	Cable Lug		
T12	MD500T315G-PLUS MD500T315G-L-PLUS	565.0	2 x (3 x 185)	BC185-16	185	BC185-16	M16	85.0 (753.1)
	MD500T355G-PLUS MD500T355G-L-PLUS	617.0						
	MD500T400G-PLUS MD500T400G-L-PLUS	687.0	2 x (3 x 240)	BC240-16	240	BC240-16	M16	85.0 (753.1)
	MD500T450G-PLUS MD500T450G-L-PLUS	782.0						

7.3.3 Wiring of Main Circuit Terminals

The following describes the requirements for the wiring of main circuit terminals. For requirements on the selection, routing, and wiring of main circuit cables, see ["7.3.4 Requirements on Wiring of the Main Circuit" on page 129](#) [Requirements on Wiring of Main Circuit Cables](#).

To prevent accidents caused by short circuits, install fuses on the input side. For requirements of fuses on the input side and recommended fuse models, see "Conditions for Compliance with the LVD" in the *MD500-PLUS Series General-Purpose AC Drive Hardware Guide*.

R, S, and T on the input side

- Input wiring does not need to follow any phase sequence requirements.
- Wiring and installation of external main circuits must comply with local regulations and related IEC requirements.
- Use copper lead wires of appropriate dimensions according to the recommendations on main circuit cable selection.

DC bus (+)/(-)

- Note that there is residual voltage at the DC bus (+)/(-) terminals upon power-off. Do not proceed with wiring until the circuit has been powered off for at least 10 minutes and the CHARGE indicator is off. Failure to comply may result in electric shock.
- When wiring an optional external braking component for a model rated at 90 kW or above, ensure correct polarity (+)/(-). Failure to comply may result in damage to the AC drive and braking components or even fire.
- Ensure that the wiring length for the braking unit does not exceed 10 m. Use twisted pair cables or tight pair cables for parallel wiring.
- Avoid connecting the braking resistor directly to the DC bus. Failure to comply may result in damage to the AC drive or even fire.

U, V, and W on the output side

- Wiring and installation of external main circuits must comply with local regulations and related IEC requirements.
- Use copper lead wires of appropriate dimensions.
- Avoid connecting the output side to a capacitor or surge protection device. Failure to comply may result in frequent triggering of the protection mechanism or even damage to the AC drive.
- An excessively long motor cable may result in electrical resonance due to the distributed capacitance. The electrical resonance may in return lead to damage to motor insulation or high leakage current, triggering the overcurrent protection mechanism of the AC drive. When using a motor cable longer than 100 m, install an AC output reactor close to the AC drive.

Grounding (PE) terminal

For grounding requirements, see "6.5 Grounding".

Wiring example (T13 models)

The following figure illustrates the wiring of main circuit terminals and grounding (PE) terminals of T13 models. For requirements and recommendations of main circuit routing, see ["7.4.4 Cable Routing Requirements" on page 144](#) and ["7.4.5 Routing Recommendations" on page 145](#).

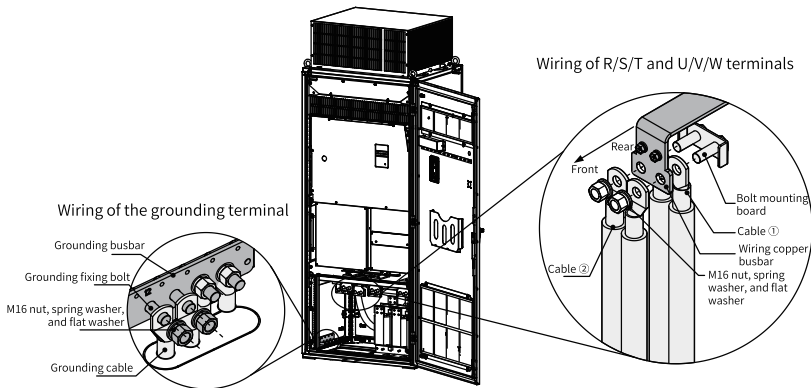

Figure 7-26 Wiring of main circuit terminals and grounding (PE) terminals



Caution

To prevent mice and insects from entering the cabinet and causing damage to the AC drive, use sealing materials such as fireproof mud to seal the cable inlet/outlet holes after wiring the main power terminal and grounding (PE) terminal.

7.3.4 Requirements on Wiring of the Main Circuit

Requirements on wiring of the main circuit

- Terminals BR, (-), and (+) are optional. Avoid connecting them to the AC power supply.
- To protect the main circuit, separate and cover the surface that may come into contact with the main circuit.
- The control circuit is a safety extra-low voltage (SELV) circuit, which must be insulated and isolated from other circuits. Make sure that the control circuit is connected to the SELV circuit.
- Prevent foreign objects from entering the wiring part of the terminal block.
- Avoid welding when using stranded wires.
- Tightening torque required by terminals may vary. Tighten the screws in accordance with applicable requirements. Use screwdrivers, ratchets, or wrenches as appropriate.
- When using an electric tool to tighten the terminal screws, set the tool to a low speed to avoid damage to the terminal screws.
- Avoid tightening the terminal screws at an angle of greater than 5 degrees. Failure to comply may result in damage to the terminal screws.

Requirements on power cable selection

Follow national or regional regulations when selecting power cables. Selection of IEC cables is based on:

- EN 60204-1 and IEC 60364-5-52 standards
- Copper wires with PVC insulation
- 40°C ambient temperature and 70°C cable surface temperature (Note: Contact the manufacturer if the ambient temperature exceeds 40°C.)
- Symmetrical cable with copper mesh shield

Note

If the recommended cables for peripheral equipment or options are not suitable for the AC drive, contact Inovance.

Shielded cables must be used to satisfy the EMC requirements. A shielded cable is either a three-core cable or a four-core cable, as shown in the following figure. If the shield of three-core cable cannot provide sufficient conductivity, add an independent PE cable, or use a four-core cable that contains a PE core. To suppress radio frequency interference effectively, use coaxial copper braid as the shielding layer of cable. The braided density of copper braid should be greater than 90% to enhance the shielding efficiency and conductivity.

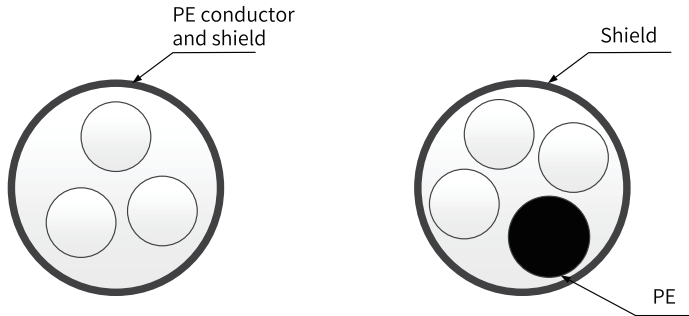

Figure 7-27 Recommended power cable types

Requirements on routing of the main circuit

The power input cable of the AC drive and the motor cable can generate strong electromagnetic interference. To avoid electromagnetic interference caused by long-distance parallel coupling between the strong interference cable and the control circuit, ensure a distance greater than 30 cm between main circuit cables and signal cables. Common main circuit cables include input R/S/T cables, output U/V/W cables, DC buses, and braking cables. Signal cables include I/O signal cables, communication cables, and encoder cables.

Cable ducts must be in good connection and well grounded. Use aluminum cable ducts to ensure the equipotentiality of the AC drive. Connect the filter, AC drive, and motor to the system (machines or devices) properly. Protect all connections with spray coating and ensure good contact of conductive metal.

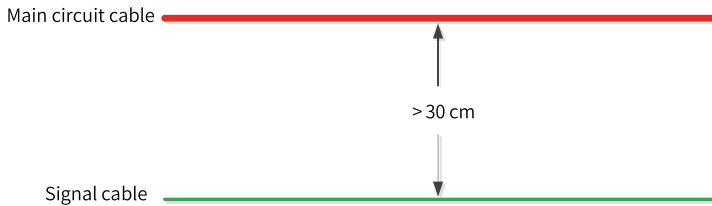

Figure 7-28 Routing of cables

Wiring in an IT or angular grid system

Before wiring in an IT or angular grid system, disconnect the optional EMS grounding screw. Failure to comply may result in damage to the AC drive or injury.

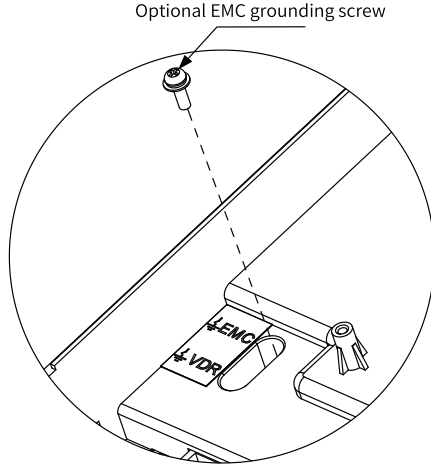

Figure 7-29 Disconnecting the optional EMC grounding screw

Motor cable shield requirements

Use shielded cables for motor output. Use a grounding bracket to achieve all-round connection with the shield, and crimp the lead wire of the shield to the PE terminal. The following figure shows the shield wiring.

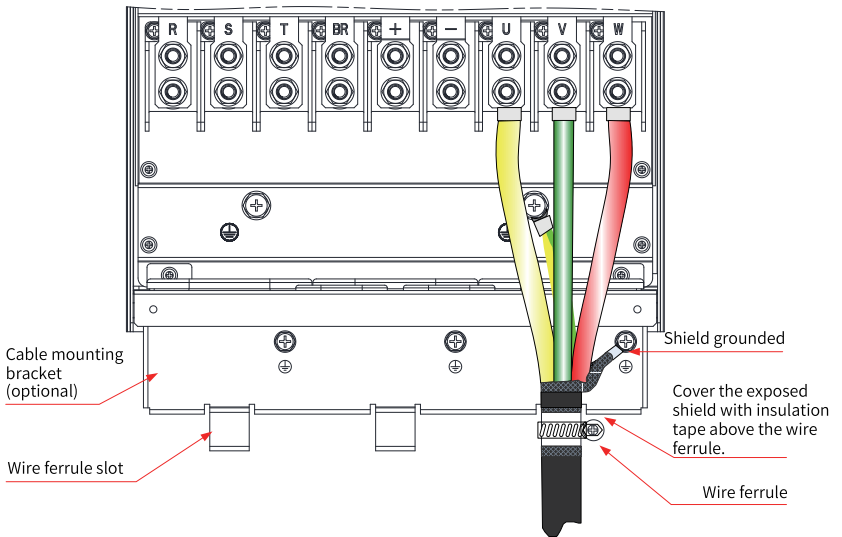

Figure 7-30 Shield wiring

For the motor cable shield, use a shortest possible lead wire with a width no less than one-fifth of the length.

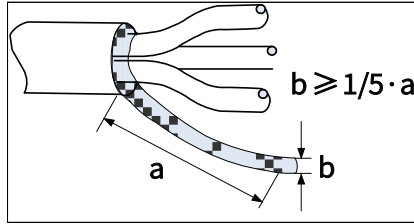

Figure 7-31 Lead wire of the motor cable shield

Motor cable length requirements

During operation of the AC drive, the quick on-off of the power switching tube can lead to excessively large dU/dt on the output side. A long motor cable may result in excessive voltage stress on the motor winding, causing insulation breakdown. Use motors that comply with IEC60034-25 IVIC B or motors with high insulation and withstand voltage. In addition, when the cable length increases, the distributed capacitance of the cable increases linearly, resulting in harmonic current.

When using a motor cable longer than the maximum length indicated in the following table, install an output reactor on the output side of the AC drive, or use a motor conforming to IEC60034-25 IVIC B. The output reactor can reduce the voltage stress on the motor winding.



Table 7-15 Requirement for output reactor based on cable length and motor types

AC Drive Rated Power (kW)	Maximum Cable Length of the Common Asynchronous Motor (m)	IEC60034-25 IVIC B Compliant	Common Asynchronous Induction Motor
0.4–3.7	50 m	Not required	Required
5.5	70 m	Not required	Required
7.5	100 m	Not required	Required
11	110 m	Not required	Required
15	125	Not required	Required
18.5	135	Not required	Required
22	150	Not required	Required
≥ 30	150	Not required	Required

Recommended cable lugs

Cable lugs recommended in the following table are GTNR series, TNR series, and BC series made by Suzhou Yuanli Metal Enterprise Co., Ltd.

Table 7-16 Appearance of cable lugs

Series	Appearance
GTNR	
TNR	
BC	

7.3.5 Protection Requirements

Main circuit cable protection requirements

Apply heat-shrink tubing to the copper lug and conductors of the cable, and ensure all conducting parts of the cable are properly wrapped, as shown in ["Figure 7-32 Applying heat-shrink tubing to conducting parts of the main circuit cable" on page 133](#).

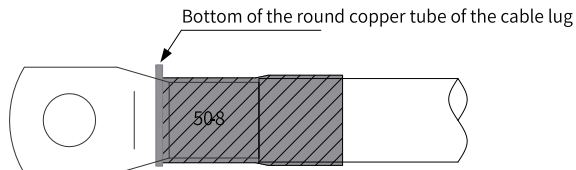

Figure 7-32 Applying heat-shrink tubing to conducting parts of the main circuit cable

Requirements for upstream protective devices

- Install appropriate protective devices on the power input side to provide overcurrent, short-circuit, and isolation protections.

- When selecting protective devices, take the following factors into consideration: current capacity of the main circuit cable, required system overload capacity, and short-circuit capacity of the upstream power input. Generally, select those recommended in the selection guide for peripheral electrical components.

7.4 Control Circuit Connection

7.4.1 Control Circuit Terminals

"Figure 7-33 " on page 134 shows the arrangement of control circuit terminals.

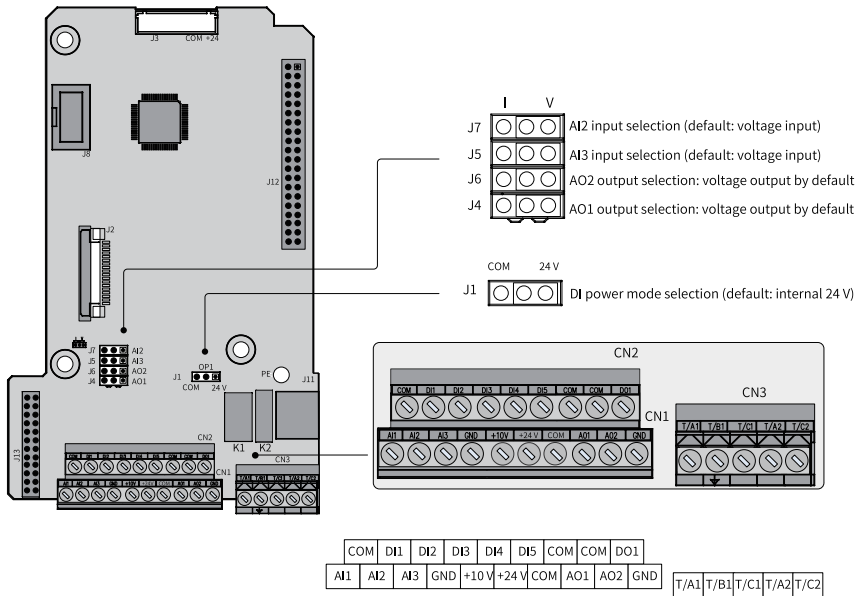

Figure 7-33 Arrangement of control circuit terminals

Table 7–17 Description of control circuit terminals

Item	Terminal Code	Terminal Name	Description
Power supply	+10 V-GND	External +10 V power supply	Provides +10 V power supply to an external unit. Its maximum output current is 10 mA. It is generally used to supply power to an external potentiometer with resistance ranging from 1 k Ω to 5 k Ω .
	+24 V-COM	External +24V power supply	Provides +24 V power supply to an external unit. It is generally used to supply power to digital input/output terminals and external sensors. Maximum output current: 200 mA
Analog input	AI1-GND	Analog input terminal 1	Input voltage range: –10 VDC to +10 VDC Input impedance: 22 k Ω
	AI2-GND	Analog input terminal 2	Input range: –10 VDC to +10 VDC or 0–20 mA, as determined by the J7 jumper on the control board Input impedance: 22 k Ω (voltage input) or 500 Ω (current input)
	AI3-GND	Analog input terminal 3	Input range: –10 VDC to +10 VDC/0–20 mA, as determined by the J5 jumper on the control board Input impedance: 22 k Ω (voltage input) or 500 Ω (current input)
Digital input	DI1-COM	Digital input 1	Photocoupler isolation enabled with an input frequency less than 100 Hz. It is driven by external or internal power as determined by the J1 jumper on the control board.
	DI2-COM	Digital input 2	
	DI3-COM	Digital input 3	
	DI4-COM	Digital input 4	
	DI5-COM	Digital input 5	Input impedance: 1.39 k Ω Voltage range with effective level input: 9–30 V
Analog output	AO1-GND	Analog output 1	Whether voltage or current is output is determined by the J4 jumper on the control board. The maximum load resistance is 500 Ω . Output voltage range: 0–10 V Output current range: 0–20 mA
	AO2-GND	Analog output 2	Whether voltage or current is output is determined by the J6 jumper on the control board. The maximum load resistance is less than 500 Ω . Output voltage range: 0–10 V Output current range: 0–20 mA

Item	Terminal Code	Terminal Name	Description
Digital output	DO1-COM	Digital output 1	Dual polarity open collector output with photocoupler isolation Output voltage range: 0–24 V Output current range: 0–50 mA
Relay output	T/A1-T/B1	Normally closed terminal	Contact driving capacity: 250 VAC, 3 A, COS ϕ = 0.4 30 VDC, 1 A
	T/A1-T/C1	Normally open terminal	
	T/A2-T/C2	Normally open terminal	
Auxiliary ports	J13	Extension card port	A 28-conductor terminal, which interfaces to optional cards (such as bus cards)
	J2	PG card port	Connects resolver and differential encoders.
	J11	Port for external operating panel	Connects an external operating panel.
Jumper	J1	DI terminal power mode selection	Determines the power mode of DI terminals. The internal 24 V power supply is used by default.
	J4	AO1 output selection	The options are voltage output (default output) and current output.
	J6	AO2 output	The options are voltage output (default output) and current output.
	J5	AI3 input selection	The options are voltage input (default input) and current input.
	J7	AI2 input selection	The options are voltage input (default input) and current input.

7.4.2 Wiring of Control Circuit Terminals

Wiring for AI

⚠ Weak analog voltage signals are prone to external interference. Therefore, a shielded cable is typically required, and the wiring distance should be as short as possible (within 20 m), as shown in ["Figure 7-34 Wiring for AI" on page 137](#). In scenarios where analog signals receive severe external interference, install a filter capacitor or a ferrite core on the analog signal source side, as shown in ["Figure 7-35 Grounding the shield of AI1" on page 137](#). Connect the lead wire of the shield of the analog input terminal to the PE terminal of the AC drive.

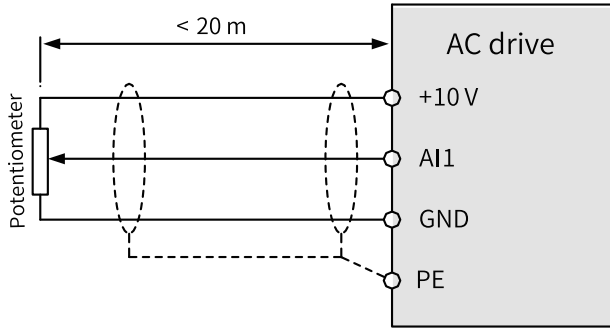

Figure 7-34 Wiring for AI

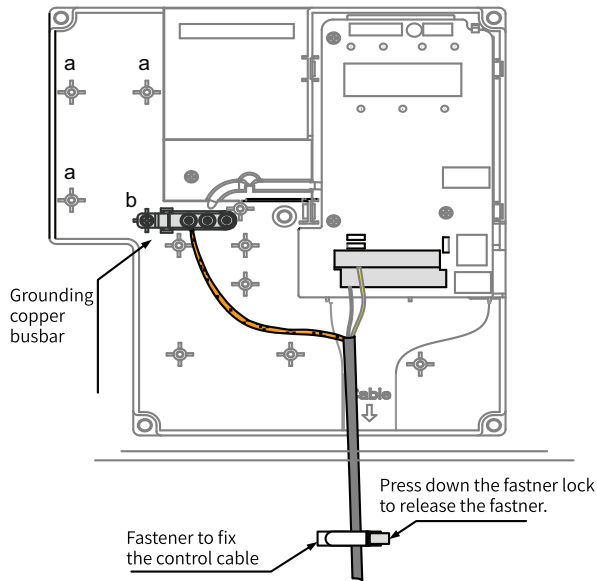

Figure 7-35 Grounding the shield of AI1

Wiring for AI2/AI3

- In the case of voltage input, wiring for AI2/AI3 is the same as that for AI1.
- In the case of current input, conduct wiring such that current flows into AI2/AI3 and out from GND, with the J7/J5 jumper set to the I side.

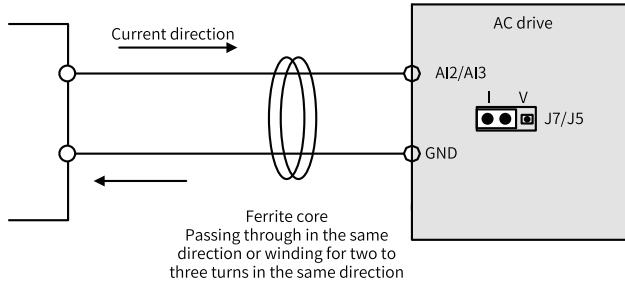
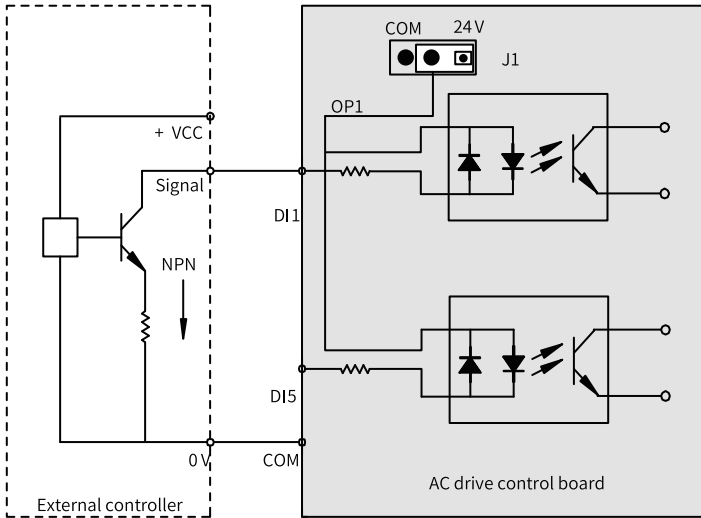

Figure 7-36 Wiring for AI2/AI3

Wiring for DI terminals (DI1 to DI5)

- Sink wiring



Sink wiring where the 24 V power supply of the AC drive is used

Figure 7-37 Sink wiring

Most commonly, these terminals use the internal 24 V power supply. For such wiring, short pins 1 and 2 of the jumper J1 on the control board of the AC drive (to short OP1 and 24V), and connect COM of the AC drive to 0V of the external controller.

This wiring method does not allow DI terminals of different AC drives to be connected in parallel because parallel connection may cause malfunction of the DI

terminals. If it is necessary to connect different DI drives (of different AC drives) in parallel, connect a diode to the applicable DI terminal in series, with the anode connected to the DI terminal. The diode must meet the following requirements: $I_F > 40\text{ mA}$ and $V_R > 40\text{ V}$. Such parallel connection is shown in "Figure 7-38 Wiring for parallel connection of DI terminals (of multiple AC drives) in sink mode" on page 139.

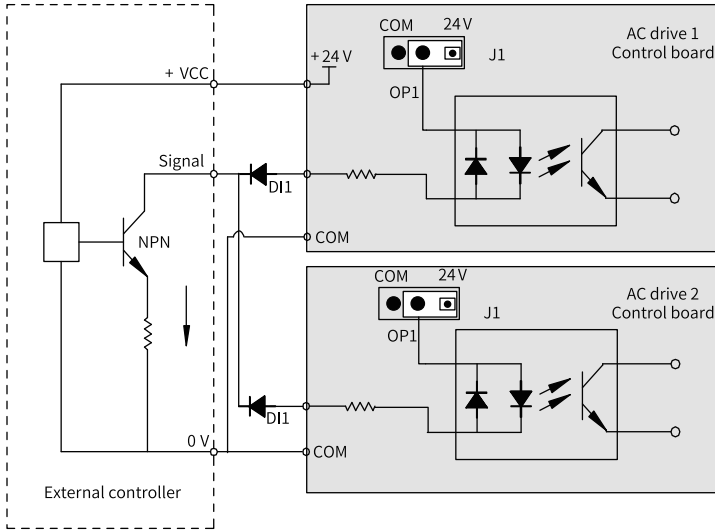
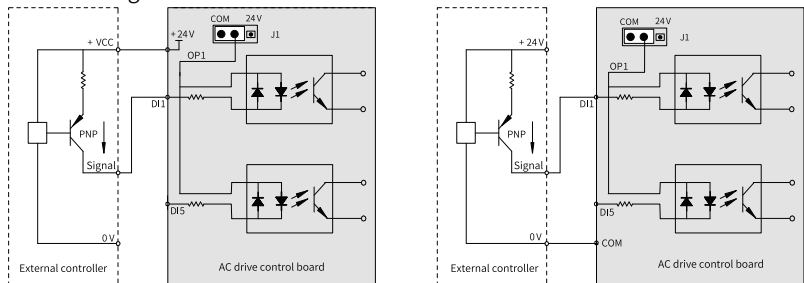

Figure 7-38 Wiring for parallel connection of DI terminals (of multiple AC drives) in sink mode

• Source wiring



Source wiring where the 24 V power supply of the AC drive is used

Source wiring where the external 24 V power supply is used

Figure 7-39 Source wiring

- To use the internal 24 V power supply of the AC drive, short pins 2 and 3 of the jumper J1 on the control board of the AC drive (to short OP1 and COM), and connect +24V of the AC drive to the power terminal of the external controller.
- To use the external power supply, short pins 2 and 3 of the jumper J1 on the control board of the AC drive (to short OP1 and COM) and connect COM of the AC drive to 0V of the controller. Connect +24V of the external power supply to the applicable DI terminal through the control contact on the external controller.

Wiring for DO terminals

When a DO terminal needs to drive a relay, connect a snubber diode across the relay coil. Otherwise, the 24 V DC power supply may be damaged. Ensure that the driving capacity does not exceed 50 mA.

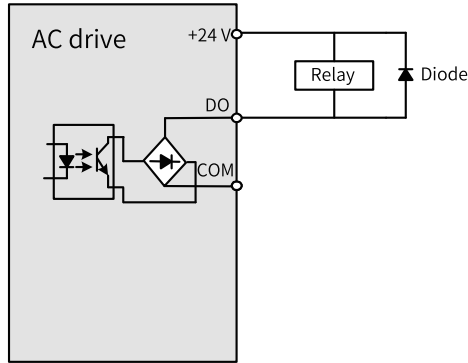

Figure 7-40 Wiring for a DO terminal

Note

Ensure correct direction of electrodes when installing the snubber diode. Failure to comply may result in burnout of the 24 VDC power supply upon output from the digital output terminal.

Wiring for relay output terminals

All inductive loads (relays, contactors, and motors) cause voltage spikes when the current is cut off. To minimize the interference at cutoff, connect a voltage dependent resistor to the relay contact and connect absorption circuits such as voltage dependent resistors, RC absorption circuits, and diodes to other inductive loads, as shown in ["Figure 7-41 Anti-interference treatment for relay output terminals" on page 141](#).

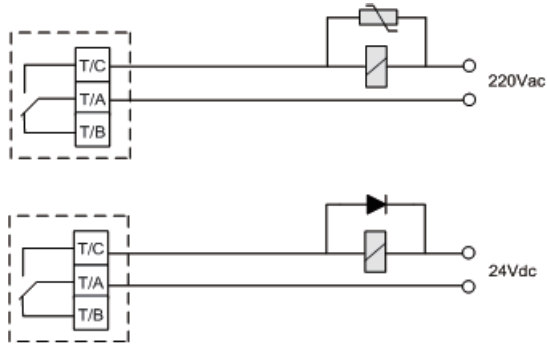

Figure 7-41 Anti-interference treatment for relay output terminals

Note

Use a category 2 power supply for the control circuit. Failure to comply may degrade the operating performance of the AC drive.

Requirements on tubular terminals

Use tubular terminals with insulating sleeves. Where applicable, keep the exposed conductor of a single wire or twisted wire no longer than 6 mm, as shown in "Figure 7-42 Requirements on the tubular terminal of a control cable" on page 141.

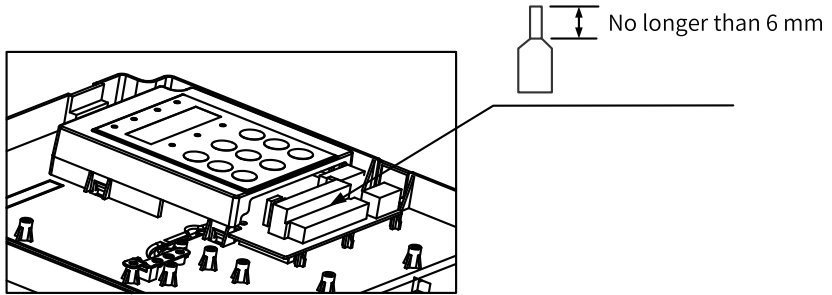

Figure 7-42 Requirements on the tubular terminal of a control cable

Table 7-18 Control cable specifications

Single Wire mm ² (AWG)	Twisted Wire mm ² (AWG)	Tightening Torque (N•m)
0.2–0.75 (AWG 24–18)		0.565

Wiring for connecting an external operating panel

To use an external operating panel, connect one end of the connecting cable to the RJ45 port of the AC drive, and lead the other end of the cable out to the operating panel from either side of the AC drive, as shown in *"Figure 7-43 Wiring for connecting an external operating panel"* on page 142.

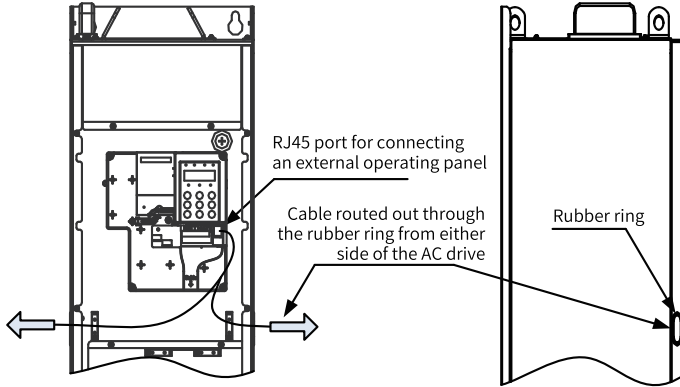

Figure 7-43 Wiring for connecting an external operating panel

7.4.3 Requirements on Selection and Routing of Control Circuit Cables

Note

Connect the control circuit cables according to EN 60204-1.

Selection requirements

To prevent peripheral interference and noise, use shielded cables for the control circuit. Install a shielding bracket at each end of the shield layer to reliably connect the cable to the AC drive. Use a separate shielded cable for each type of analog signal. Use shielded twisted pair cables for digital signals.

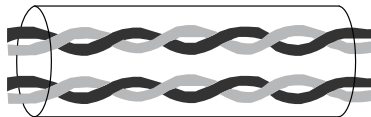

Figure 7-44 Shielded twisted pair cables

Requirements on shield grounding for analog terminals

Weak analog voltage signals are susceptible to external interference. Therefore, a shielded cable is typically required, and the wiring distance should be as short as

possible (within 20 m). In scenarios where analog signals suffer from severe external interference, install a filter capacitor or a ferrite core on the analog signal source side.

- Use shielded cables together with a shield grounding bracket (optional) to achieve all-round grounding of the cable shield can.
- Minimize the length of the lead wire of the shield. Fasten the lead wire to the standard grounding copper busbar of the AC drive by using screws. The following figure shows the grounding.

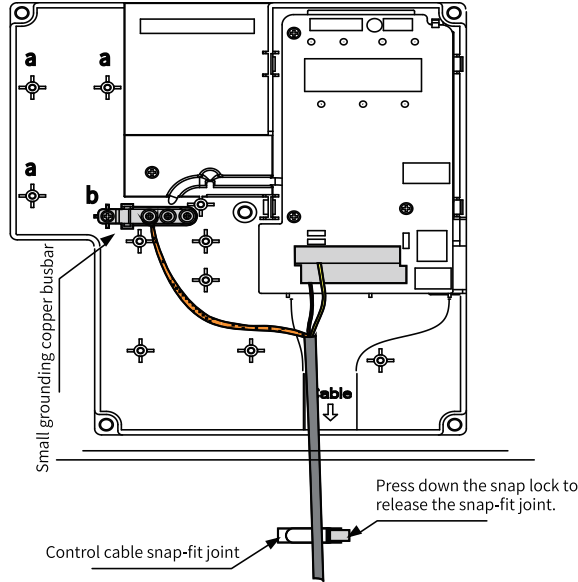

Figure 7-45 Grounding the shield of AI1

Requirements on wiring of encoder signal cables

Before inserting a PG card, remove the screws shown in the enlarged area in the following figure, align the PG card with the three fixing posts (to the upper left of the enlarged area), and fix the PG card with M3 x 8 screws.

The entire AC drive is grounded in structure. When wiring the encoder after PG card installation, connect the encoder signal cable shield to the PE terminal of the PG card to complete shield grounding. Wire the encoder in accordance with the following requirements:

1. During on-site installation and commissioning, route the encoder cable and power cable in different cable ducts. Failure to comply may result in encoder interference.
2. Use shielded twisted pair cables. For differential encoders, connect the shield of the twisted pair cable to the grounding (PE) terminal of the AC drive.
3. In some scenarios with large-scale equipment, where the AC driver is far away from the motor (the motor cable may be as long as 10 m), the grounding impedance of

the encoder cable shield is increased due to parasitic inductance of the cable. In this case, you can disconnect the encoder shield from the grounding (PE) terminal of the AC drive.

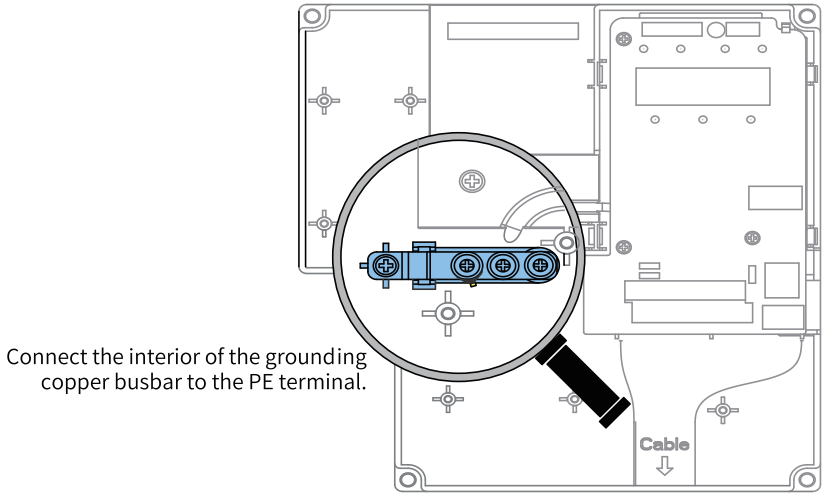

Connect the interior of the grounding copper busbar to the PE terminal.

Figure 7-46 PG card installation screws

I/O signal cable routing requirements

- I/O signals include analog input (AI) signals, analog output (AO) signals, digital input (DI) signals, digital output (DO) signals, and relay output signals. Before wiring the I/O terminals, disconnect the main power supply and ensure that the danger indicator of the AC drive is off.
- Separate I/O signal cables from the main circuit cables (RST and UVV) and other power cables (or electric power cables) by a distance of at least 30 cm. Failure to comply may result in interference to I/O signals.
- Separate the cable connecting the relay output terminal from other I/O signal cables by a distance greater than 30 cm. Failure to comply may result in malfunction of the AC drive and equipment.

7.4.4 Cable Routing Requirements

1. Separate signal cables from power cables
 When analog signals are used for remote control on the cabinet module, separate signal cables from high-voltage circuits (power input, inverter output, and braking resistor connection cables) by a distance above 50 cm to reduce interference of analog signals from the AC drive and other equipment. Comply with the preceding requirements even in the control cabinet.
2. Analog control signal cable requirements

Use shielded twisted pair cables. Minimize the length of unshielded part of the cable (about 5–7 mm) and wrap the exposed part with insulation tape to prevent the shielded cable from coming into contact with other equipment and incurring interference.

3. Motor cable requirements

Use shielded cables. Minimize the distance between the cabinet module and the motor, and route the motor cables routed independently of other cables. Also, avoid long-distance parallel routing of the motor cables and other cables to reduce electromagnetic interference caused by rapid changes in the output voltage of the AC drive.

4. Power cable requirements

Use shielded cables, or shield all the cables from the cabinet module to the motor by using wire tubes.

5. Requirements of control cables and power cables

When the power cables and control cables must be intersected, the intersection angle shall be 90 degrees.

7.4.5 Routing Recommendations

Routing for disturbing cables and sensitive cables

During routing, separate cables that transmit different types of signals. Separate the disturbing cables from sensitive cables by a distance of 30 cm wherever possible. When two types of cables must be intersected, the intersection angle shall be 90 degrees to avoid interference, as shown in the following figure.

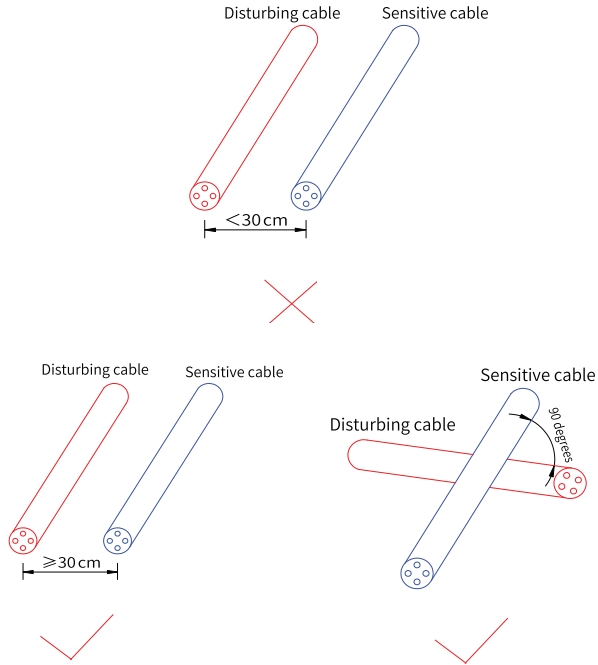

Figure 7-47 Routing for disturbing cables and sensitive cables

Routing for cables that transmit different types of signals

Arrange cables that transmit different types of signals through different routes and separate different types of signals with equipotential signals. When routing cables that transmit the same type of signals, the equipotential signal cable stays in the outer layer and equipotential signals should stay in the middle if possible, as shown in the following figure.

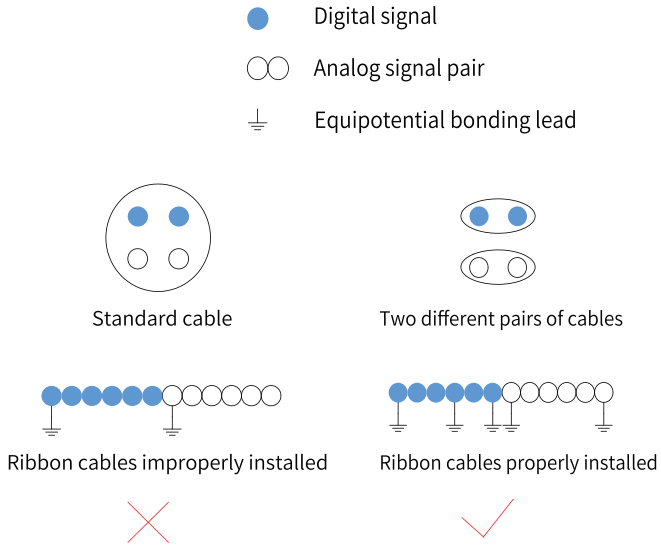

Figure 7-48 Routing for cables that transmit different types of signals

Routing for multi-conductor cables

For multi-conductor cables, use one cable to transmit one type of signals. To use one cable to transmit different types of signals, use a cable with internal conductor shielded, as shown in the following figure.

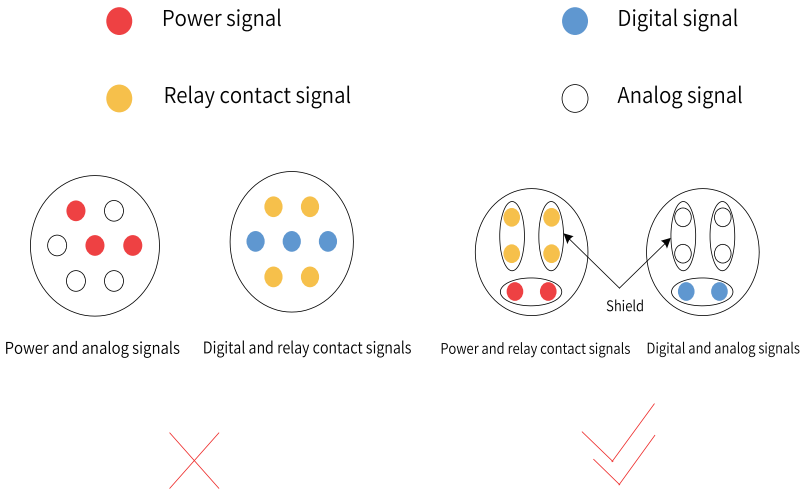

Figure 7-49 Routing for multi-conductor cables

If a multi-conductor cable used to connect the equipment has any idle conductors, connect all the idle (or spare) conductors to the equipotential bonding point, as shown in the following figure.

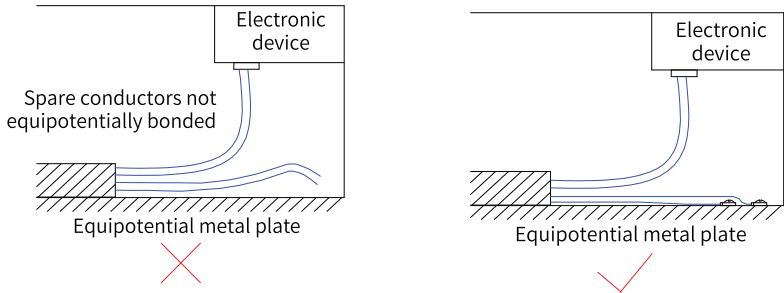

Figure 7-50 Treatment when a multi-conductor cable has any idle core wires

Avoiding large loop area

For low-level sensor signals and the relay signals sharing a common line, route two cables as close as possible to prevent a large loop area. For analog signals, use twisted pairs. For digital signals, ensure signal cables are routed close to each other.

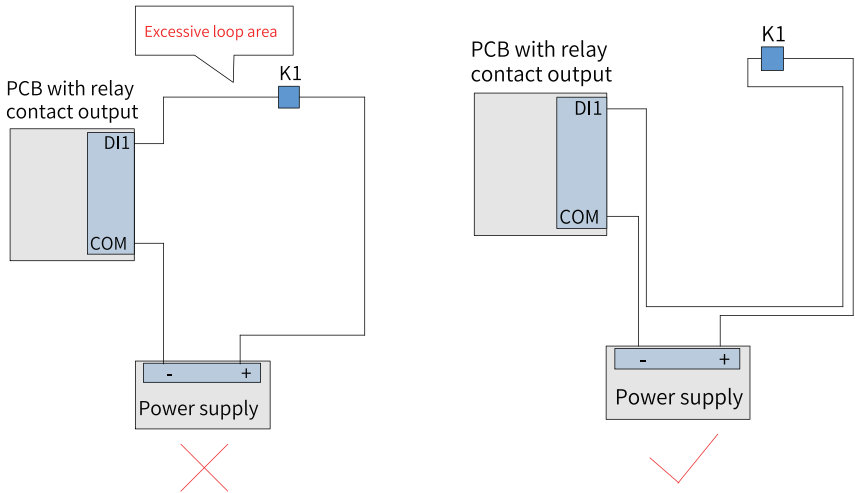

Figure 7-51 Avoiding large loop area

Laying multiple types of cables

For cables of different types, route the cables along the equipotential metal plate. Separating different types of cables or separating cables in the same metal (zinc-iron or stainless steel) duct with metal separators can enhance the internal EMC performance.

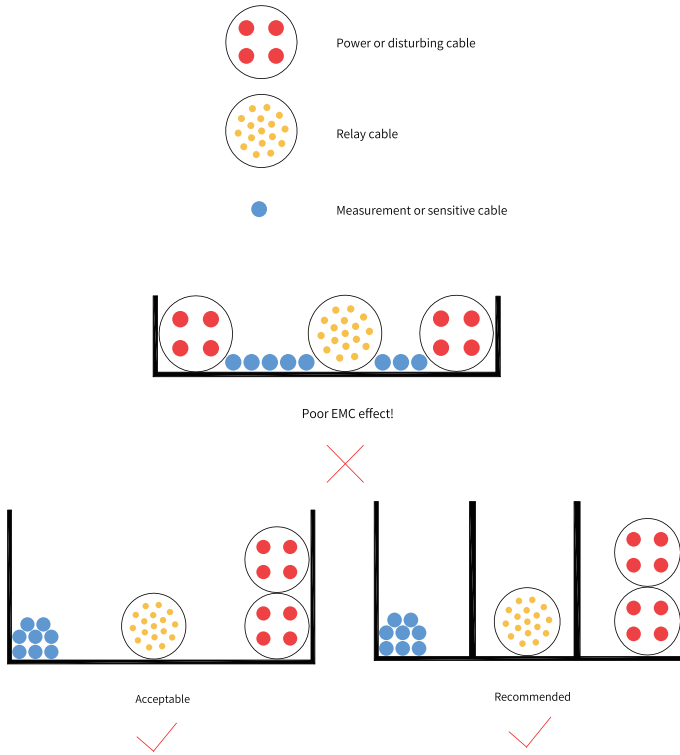

Figure 7-52 Laying multiple types of cables

Requirements on treatment of shielded cables

Keep the unshielded part of the shielded cable as short as possible. Connect the shield to the nearest PE terminal. Note that if the stripped sheath is too long, the conductor may be prone to signal interference, especially the encoder signals.

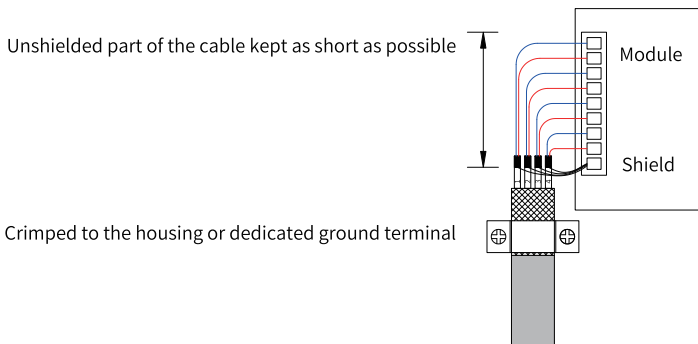

Figure 7-53 Requirements on treatment of shielded cables

7.5 Grounding

7.5.1 Grounding Requirements

To correctly ground the AC drive, observe the following requirements:



- Ground the grounding terminal to avoid electric shock. Comply with the relevant local electrical regulations for grounding.
 - To prevent electric shocks, check that the protective grounding conductor meets the technical specifications and local safety standards, and use a shortest possible grounding cable. The leakage current of the AC drive can be over 3.5 mA. Use a copper wire with a cross-sectional area of at least 10 mm² for the protective grounding, or use two protective grounding conductors of the same specifications for connection according to EN 61800-5-1.
 - Follow the instructions for grounding every AC drive when multiple AC drives are installed. Incorrect grounding may lead to malfunction of AC drives.
 - Disconnect the optional grounding screw of VDR (available on the AC drive) before the voltage resistance test. Failure to comply may fail the test.
-
- Use a proper yellow-green copper cable for the protective grounding conductor, and avoid connecting it to switchgears such as circuit breakers in series.
 - Reliably ground the grounding terminal. Failure to comply may result in abnormal operation of the AC drive and even damage.
 - Avoid connecting the grounding (PE) terminal to the N terminal of the neutral wire of the power supply.
 - Mount the equipment onto a conductive metal surface (recommended) to ensure well connection between the entire conductive bottom of the equipment and the mounting surface.
 - Fasten the grounding screws using the recommended tightening torque to avoid loose or excessively tight fixing of the protective grounding conductor.

7.5.2 Grounding One AC Drive Alone

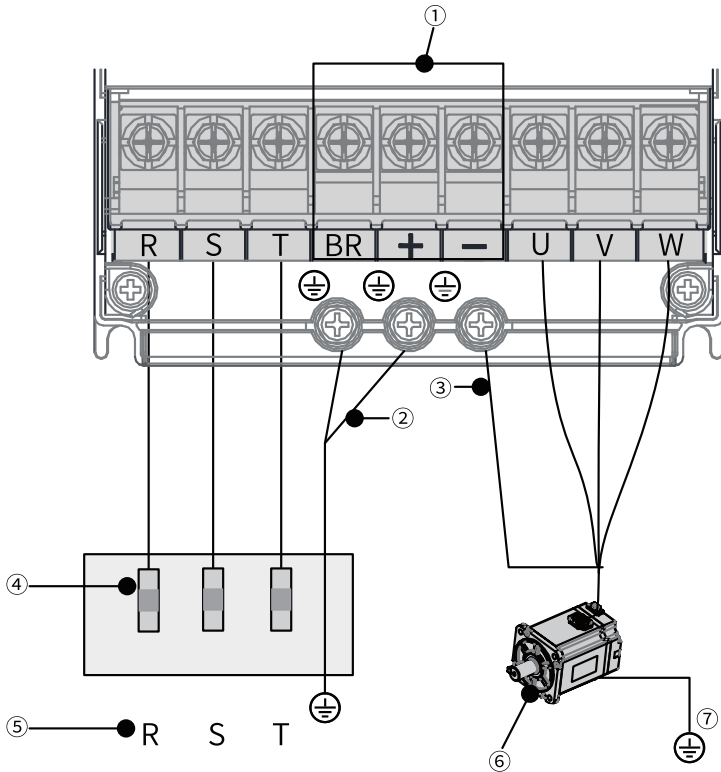

Figure 7-54 Main circuit grounding

Table 7-19 Main circuit grounding

No.	Wiring Description
①	Avoid grounding the DC bus terminal and braking resistor terminal.
②	Connect the PE terminal on the power supply side to the PE terminal on the input side of the AC drive.
③	Connect the PE terminal on the output side of the AC drive to the motor output cable shield.
④	Input protection (fuse with its lower part connected to the filter)
⑤	Power supply

No.	Wiring Description
⑥	Three-phase motor
⑦	Ground the motor enclosure.

Note

Arrangement of the main circuit terminals varies with models.

7.5.3 Grounding Multiple AC Drives Installed Side by Side

The following figure shows the grounding when multiple AC drives are installed in the cabinet side by side.

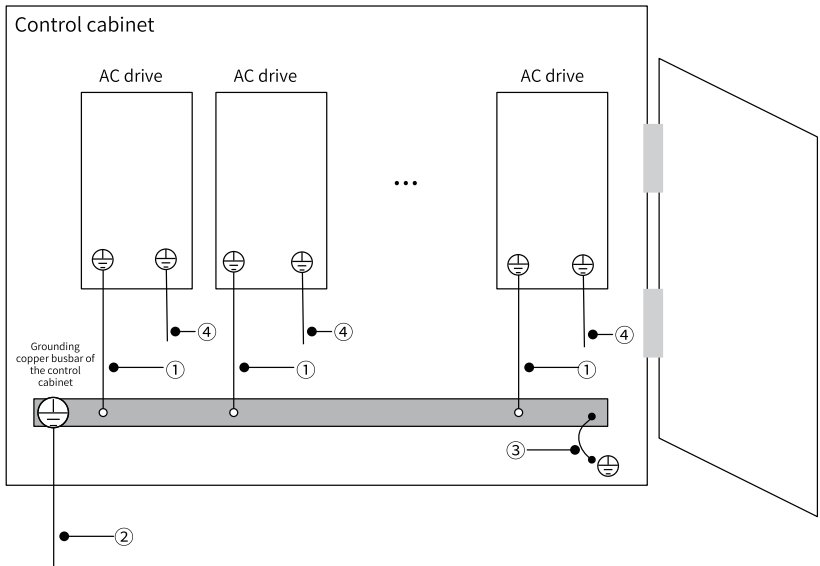

Figure 7-55 Grounding multiple AC drives installed side by side

Table 7-20 Grounding multiple AC drives installed side by side

No.	Wiring Description
①	Connect the PE terminal on the input side of the main circuit to the grounding copper busbar of the control cabinet through a protective grounding conductor.
②	Connect the PE terminal on the power supply side to the grounding copper busbar of the control cabinet.

No.	Wiring Description
③	Connect the grounding copper busbar of the control cabinet to the metal housing through a protective grounding conductor.
④	Connect the motor output cable shield to the PE terminal on the output side of the product.

7.5.4 Grounding the Cabinet System

The most cost-effective method of suppressing interference in a cabinet is to isolate the interference source from the equipment that may be interfered with. Divide a cabinet into multiple EMC compartments or use multiple cabinets based on the intensity interference sources, and install each device in accordance with the following wiring principles.

Table 7-21 Wiring principles

No.	Wiring principles
1	Place the control unit and the drive unit in two separate cabinets.
2	If multiple cabinets are used, connect the cabinets by using a PE cable with a cross-sectional area of at least 16 mm ² for equipotentiality between the cabinets.
3	If only one cabinet is used, place the devices in different compartments of the cabinet based on signal intensity.
4	Perform equipotential bonding for devices in different compartments of the cabinet.
5	Shield all communication (such as RS485) and signal cables drawn from the electric cabinet.
6	Place the power input filter in a position near the input interface of the cabinet.
7	Provide spray coating protection for all grounding points in the cabinet.

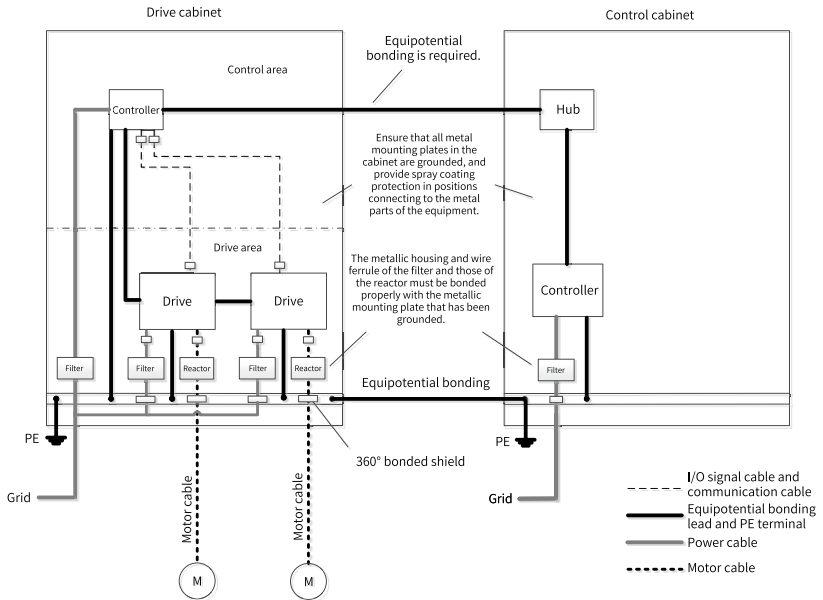

Figure 7-56 Recommended wiring for the cabinet system

7.6 Communication Connection

7.6.1 RS485 Wiring

RS485 communication connection with PLC

Use a three-conductor shielded cable to connect the RS485 bus, with the three conductors connected to 485+, 485-, and GND respectively. Connect 485+ and 485- with two conductors twisted together and connect the remaining conductor to the reference ground (CGND) of RS485. Connect the shield to the device GND. Connect a 120 Ω termination resistor on each end of the bus to prevent RS485 signal reflection.

Table 7–22 Cable pin connections for communication between PLC and the AC drive

AC Drive			PLC		
Communication Type	Signal	Description	Communication Type	Signal	Description
RS485	RS485+	RS485 signal (+)	RS485	RS485+	RS485 signal (+)
	RS485-	RS485 signal (-)		RS485-	RS485 signal (-)
	CGND	Signal reference ground		CGND	Signal reference ground
-	PE (shield)	Enclosure	-	PE (shield)	Enclosure

RS485 communication connection for multiple AC drives in parallel

The following table specifies the cable pin connections for multiple AC drives in parallel in RS485 communication networking.

Table 7–23 Cable pin connections for communication between multiple AC drives in parallel

AC Drive (Side A)			AC Drive (Side B)		
Communication Type	Signal	Description	Communication Type	Signal	Description
RS485	RS485+	RS485 signal (+)	RS485	RS485+	RS485 signal (+)
	RS485-	RS485 signal (-)		RS485-	RS485 signal (-)
	CGND	Signal reference ground		CGND	Signal reference ground
-	PE (shield)	Enclosure	-	PE (shield)	Enclosure

Communication networking

Use the daisy chain topology for the RS485 bus in the case of a large number of nodes, as shown in the following figure. Ensure that the RS485 signal reference ground of all nodes are connected together. A maximum of 128 nodes can be connected.

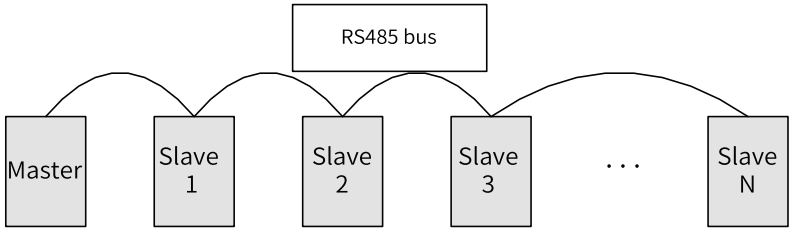

Figure 7-57 Daisy chain connection

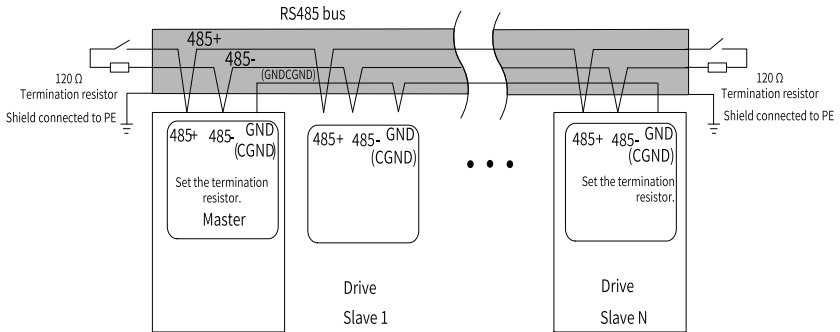

Figure 7-58 RS485 bus topology

The maximum allowable number of nodes and transmission distance of a standard RS485 circuit vary with transmission rates, as listed in the following table.

Table 7-24 Transmission distance and number of nodes

Transmission Distance (m)	Rate (kbps)	Number of Nodes	Cable Specification
100	115.2	128	AWG 26
1000	19.2	128	AWG 26

7.6.2 CAN Communication Wiring

CAN communication with PLC

Use a three-conductor shielded cable for the CAN bus. The AC drive comes with three cables for connection to the CANH, CANL, and CGND terminals. The cables for CANH and CANL connection are twisted pair cables. For the third cable, the conductor is connected to the CAN reference ground CGND, and the shield is connected to the equipment ground. Connect 120 Ω termination resistors only at the head and tail ends of the bus to prevent CAN signal reflection.

The following table specifies the cable pin connections for the communication between the AC drive and PLC in CAN communication networking.

Table 7–25 Cable pin connections for communication between PLC and the AC drive

AC Drive			PLC		
Communication Type	Signal	Description	Communication Type	Signal	Description
CAN	CANH	CAN signal (+)	CAN	CANH	CAN signal (+)
	CANL	CAN signal (-)		CANL	CAN signal (-)
	CGND	Signal reference ground		CGND	Signal reference ground
-	PE (shield)	Enclosure	-	PE (shield)	Enclosure

CAN communication connection for multiple AC drives in parallel

The following table specifies the cable pin connections for multiple AC drives in parallel in CAN communication networking.

Table 7–26 Cable pin connections for communication between multiple AC drives in parallel

AC Drive (Side A)			AC Drive (Side B)		
Communication Type	Signal	Description	Communication Type	Signal	Description
CAN	CANH	CAN signal (+)	CAN	CANH	CAN signal (+)
	CANL	CAN signal (-)		CANL	CAN signal (-)
	CGND	Signal reference ground		CGND	Signal reference ground
-	PE (shield)	Enclosure	-	PE (shield)	Enclosure

Communication networking

Use the daisy chain topology for the CAN bus. The following figure shows the CAN bus topology. Use shielded twisted pair cables for the CAN bus and twisted pair cables for CANH and CANL. Connect 120 Ω termination resistors only at both ends of the bus to prevent signal reflection. Ensure that the CAN signal reference ground of all nodes are connected together. A maximum of 64 nodes can be connected.

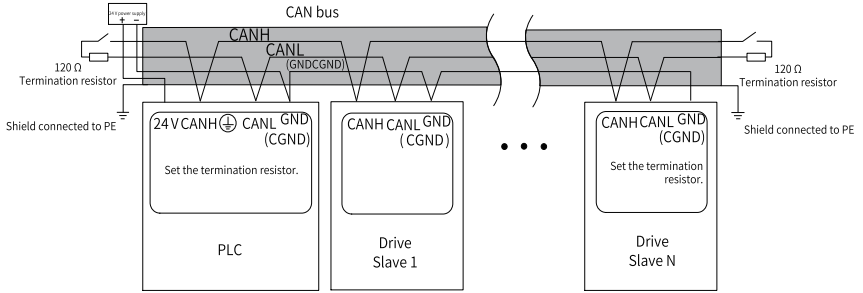

Figure 7-59 CAN bus topology

The transmission distance of CAN bus is directly dependent on the baud rate and communication cable. The mapping between the maximum transmission distance of CAN bus and the baud rate is described in the following table.

Table 7-27 Transmission distance and rate

Transmission Distance (m)	Rate (kbps)	Number of Nodes	Cable Diameter
25	1024	64	0.205 mm ²
95	500	64	0.34 mm ²
560	100	64	0.5 mm ²
1100	50	64	0.75 mm ²

7.6.3 EtherCAT Wiring

Use standard RJ45 network ports and standard registered jacks for the EtherCAT bus. Use Cat 5e shielded twisted pair cables and injection molding wires with iron shells. As verified by FastEthernet technology, when the EtherCAT bus is used, the cable between equipment shall not exceed 100 m. Failure to comply may result in signal attenuation, affecting normal communication.

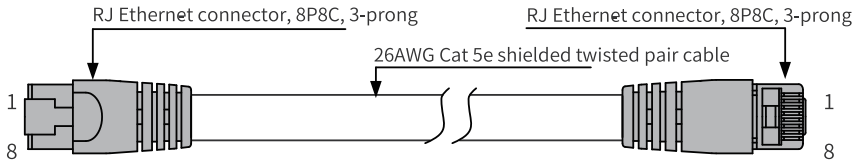

Figure 7-60 Requirements on fabrication of EtherCAT network cables

Use shielded cables for network data transmission for the EtherCAT bus. Network cables of the specifications specified in the following table are recommended.

Table 7–28 EtherCAT cable specifications

Item	Specifications
Cable type	Elastic crossover cable, S-FTP, Cat 5e
Standard compliance	EIA/TIA568A, EN50173, ISO/IEC11801 EIA/TI Abulletin TSB, EIA/TIA SB40-A&TSB36
Lead wire cross section	AWG 26
Lead wire type	Twisted pair cable
Pair	4

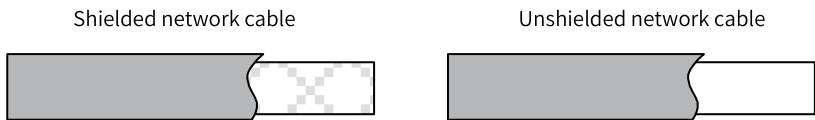

Figure 7-61 Shielded network cables

During wiring, hold the registered jack of the RJ45 network cable and insert it in the RJ45 port of the communication module until you hear a click sound. To remove the RJ45 network cable, press and hold the tail of the registered jack, and pull it out along the direction parallel with the module.

To avoid the influence of other stress on the communication cable and ensure the stability of communication, fasten the cable near the equipment before starting EtherCAT communication.

7.6.4 PROFINET Wiring

After communication between the MD500-PN1 card and the AC drive is implemented, connect the AC drive to the PROFINET master station and configure related parameters to implement communication between the MD500-PN1 card and the PROFINET master station, thereby implementing AC drive networking.

PROFINET supports a variety of topologies, including bus, star, and tree topologies. Different networking modes can be implemented by using switches.

A ring or linear topology can be implemented by using two ports on the AC drive. In this case, connect the head and tail of the cable to only one of the two ports. The cable between two nodes can be up to 100 m.

Note

Use the external 24 VDC power supply connected to the terminal to supply power to the AC drive if the communication still needs to be maintained when the main power supply is disconnected.

7.7 Inspection After Wiring

After the wiring is completed, check the items in the following checklist one by one and put a tick for compliance.

Table 7-29 Wiring checklist

No.	Checklist	Compliance
1	The power input is connected to the R, S, and T terminals properly.	
2	The motor input cable is connected to the U, V, and W terminals properly.	
3	The diameter of the main circuit cable meets the requirement.	
4	Heat-shrink tubing is applied to the copper lug and conductors of the main circuit cable and the tubing completely wraps the conducting parts of the cable.	
5	Motor output cable does not exceed 50 m, or the carrier frequency (F0-15) is reduced for a motor output cable exceeding 50 m.	
6	The AC drive is properly grounded.	
7	The output terminals and control cable terminals are connected securely and reliably.	
8	Where applicable, the braking resistor and braking unit used are wired properly with proper resistance values.	
9	Shielded twisted pair cables are used as control circuit signal cables.	
10	Optional cards are properly connected.	
11	The control circuit cable and main circuit power cable are routed separately.	

8 Installation of Options

8.1 AC Input Reactor

An AC input reactor is used to suppress harmonic waves in the input current. Install an AC reactor for applications with strict requirements on harmonic suppression to meet the requirements in IEC/EN 61000-3-2/12.

To install an AC input reactor, ensure sufficient space in the cabinet.

8.2 Output Reactor

An output reactor installed on the output side of the AC drive can reduce dV/dt and voltage stress on the motor winding, protecting the motor winding, reducing the motor temperature, and prolonging the motor service life.

8.3 Fuses, Contactors, and Circuit Breakers



If the fuse is blown or the circuit breaker trips, wait for at least a period of time specified on the equipment warning label before energizing the AC drive or operating any peripheral equipment. Failure to comply may result in equipment damage, personal injury, or even death.

To meet the requirements in IEC/EN 61800-5-1 and UL61800-5-1, install a fuse or circuit breaker on the input side to prevent accidents caused by internal short circuits.

8.4 EMC Filter

Use an optional EMC filter to meet category C2 emission requirements in EN 61800-3 of CE certification. For details about models and dimensions, see the *MD500-PLUS Series AC Drive Selection Guide*. Install the EMC filter according to the following requirements:

- Install the EMC filter close to the input terminals of the AC drive by using a cable shorter than 30 cm.
- Connect the grounding (PE) terminal of the EMC filter to that of the AC drive, and install the filter and the AC drive on the same conductive mounting surface, which is connected to the main grounding wire of the cabinet.
- Connect the LINE terminal of the EMC filter to the grid, and the LOAD terminal to the AC drive.

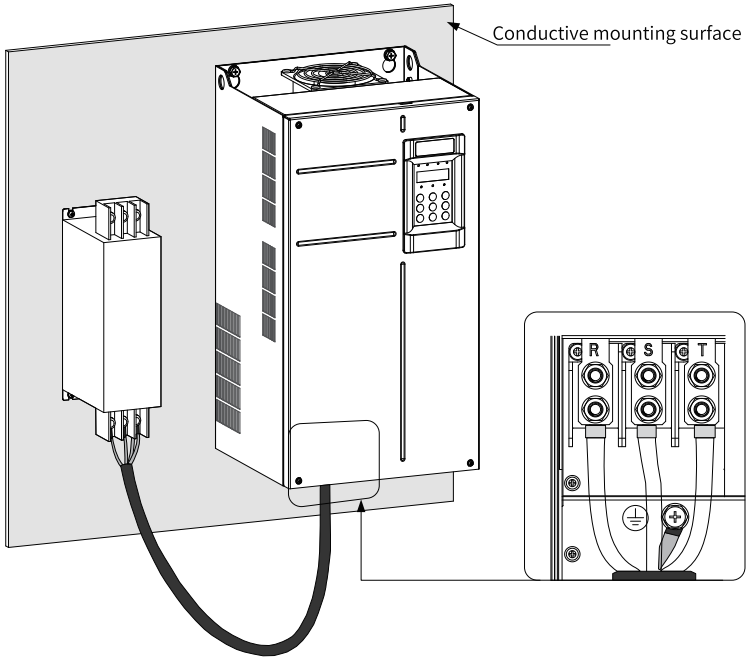

Figure 8-1 Installing an EMC filter

8.5 Simple Filter

Using a simple filter (capacitor box) instead of a standard EMC filter can also suppress RF electromagnetic noise from the grid and generated by the AC drive during operation. Reliably ground the simple filter and ensure that the cable between the filter and the AC drive is shorter than 30 cm.

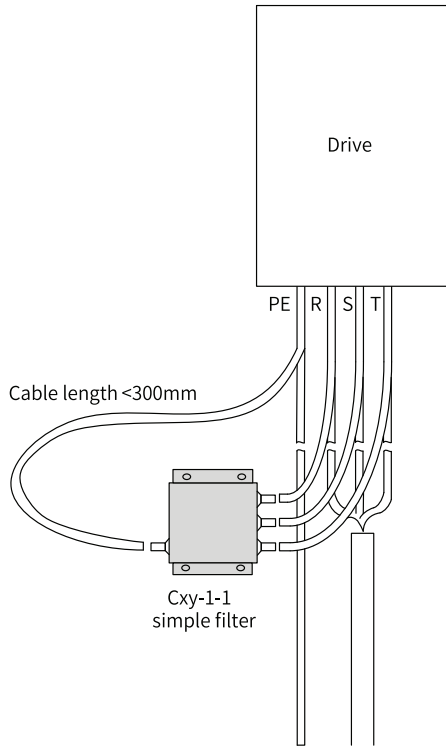

Figure 8-2 Installing a simple filter

8.6 Magnetic Ring and Ferrite Clamp

A magnetic ring can be installed on the input or output side of the AC drive. Install it as close to the AC drive as possible. A magnetic ring installed on the input side can suppress noise in the input power supply system of the AC. A magnetic ring installed on the output side can suppress interference generated by the AC drive to external devices and reduce the bearing current.

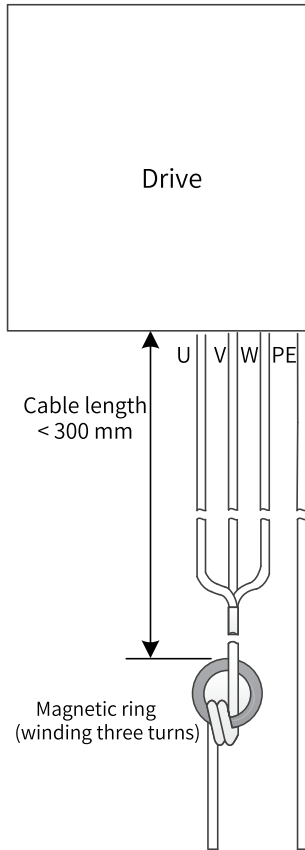

Figure 8-3 Installing a magnetic ring

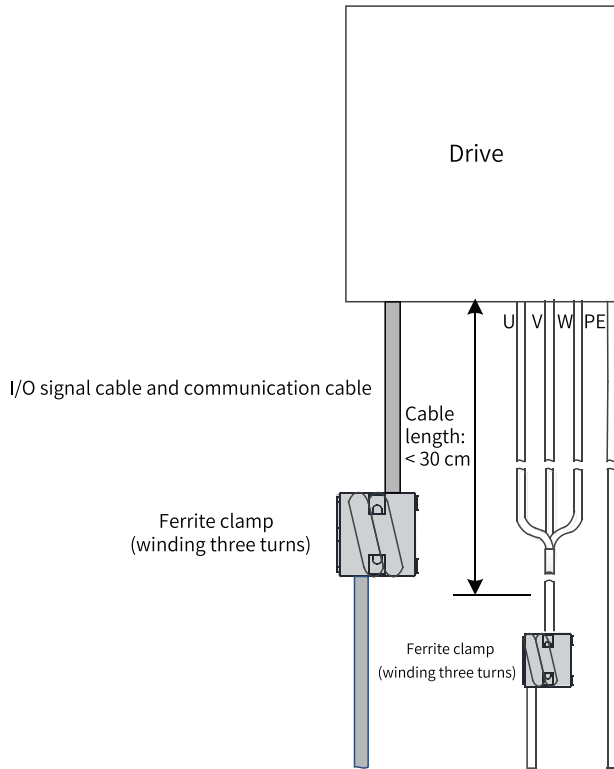

Figure 8-4 Installing a ferrite clamp

Note

The R/S/T or U/V/W cables must pass through the same magnetic ring to suppress the common mode noise.

9 Troubleshooting for Common EMC Interference

Problems

9.1 Leakage Current Suppression

The drive outputs high-speed pulse voltage, which may easily incur high-frequency leakage current. The leakage current generated by each drive is higher than 100 mA. The rated action current of the earth leakage circuit breaker (ELCB) therefore must be above 100 mA. The drive may generate DC leakage current in the protective conductor, a B-type (delay-time) ELCB therefore must be used.

If multiple drives are used, install an ELCB to each drive. The factors that affect the leakage current are as follows:

- AC drive capacity
- Carrier frequency
- Type and length of the motor cable
- EMI filter

When leakage current causes the circuit breaker to trip, you should:

- Increase the rated operating current of the circuit breaker.
- Replace the circuit breaker with a new one with high-frequency suppression.
- Reduce the carrier frequency.
- Shorten the output drive cable.
- Install a current leakage suppression device.
- Use a circuit breaker from recommended manufacturers such as Chint Electric and Schneider.

9.2 Earth leakage Circuit Breaker Malfunction

When an earth leakage circuit breaker malfunctions, perform troubleshooting according to the following table.

Table 9-1 Troubleshooting for leakage current

Symptom	Possible Cause	Action
Trip upon power-on	The anti-interference performance of the earth leakage circuit breaker is poor.	<ol style="list-style-type: none"> 1. Use an earth leakage circuit breaker from a recommended manufacturer. 2. Use an earth leakage circuit breaker with greater operating current. 3. Move the unbalanced load to the front end of the earth leakage circuit breaker. 4. Remove the EMC screw or disconnect the grounding terminal of the external EMC filter to reduce the capacitance of the input end to the ground.
	The operating current of the earth leakage circuit breaker is too low.	
	Unbalanced load is connected to the back end of the earth leakage circuit breaker.	
	The capacitance to the ground at the front end of the AC drive is large.	
Trip during operation	The anti-interference performance of the earth leakage circuit breaker is poor.	<ol style="list-style-type: none"> 1. Use an earth leakage circuit breaker from a recommended manufacturer. 2. For an individual AC drive, tighten the EMC screw. For multiple AD drives, disconnect the optional EMC grounding screw, as shown in "Figure 9-1 Disconnecting the optional EMC grounding screw" on page 168. 3. Install a simple filter on the input side of the AC drive, and wind the LN/RST cable on a magnetic ring near the earth leakage circuit breaker, as shown in "Figure 9-2 Installing a simple filter and magnetic ring on the input side" on page 168. 4. Use an earth leakage circuit breaker with greater rated operating current. 5. Reduce the carrier frequency while ensuring performance. 6. Use shorter motor cables.
	The operating current of the earth leakage circuit breaker is too low.	
	Unbalanced load is connected to the back end of the earth leakage circuit breaker.	
	The distributed capacitance to the ground of the motor cables and motors is large.	

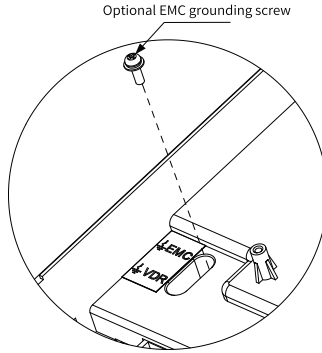

Figure 9-1 Disconnecting the optional EMC grounding screw

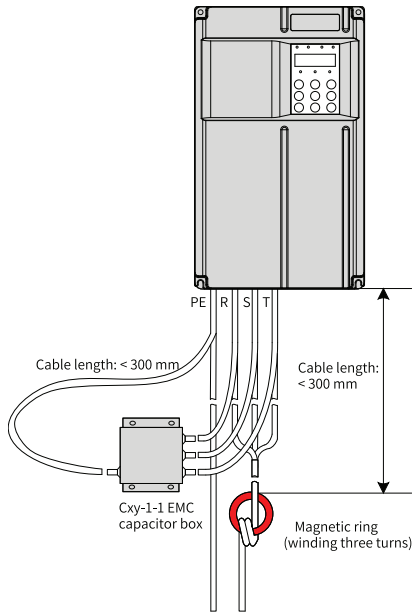

Figure 9-2 Installing a simple filter and magnetic ring on the input side

9.3 Harmonic Suppression

To suppress the harmonic current of the AC drive and improve the power factor, install an AC input reactor on the input side of the AC drive to meet standard requirements.

9.4 Control Circuit Interference

9.4.1 High-Speed Pulse Interference

Follow the following table for troubleshooting.

Step	Action
1	Use a shielded twisted-pair cable and ground it at both ends.
2	Connect the motor enclosure to the PE terminal of the AC drive.
3	Connect the PE terminal of the AC drive to the PE terminal of the grid.
4	Add an equipotential bonding grounding wire between the host controller and the AC drive.
5	Separate the signal cable from the power cable by a distance of at least 30 cm.
6	Add a ferrite clamp to the signal cable, or wind the signal cable on a magnetic ring for one to two turns.
7	Wind the output U/V/W cables of the AC drive on a magnetic ring for two to four turns.
8	Use a shielded power cable and ensure that the shield is well-grounded.

9.4.2 Common I/O Signal Interference

The AC drive generates very strong interference. Despite EMC measures taken, the interference may still exist due to improper routing or grounding. When the AC drive interferes with other equipment, follow the following table for troubleshooting.

Step	Action
1	Use shielded cables as the I/O signal cables, with the shield connected to the PE terminal.
2	Reliably connect the PE terminal of the motor to the PE terminal of the AC drive, and connect the PE terminal of the AC drive to the PE terminal of the grid.
3	Add an equipotential bonding grounding wire between the host controller and the AC drive.
4	Wind the output U/V/W cables of the AC drive on a magnetic ring for two to four turns.
5	Increase capacitance at low-speed DI. The upper limit of capacitance is 0.1 μF .
6	Increase capacitance at AI. The upper limit of capacitance is 0.22 μF .

Step	Action
7	Add a ferrite clamp to the signal cable, or wind the signal cable on a magnetic ring for one to two turns.
8	Use a shielded power cable and ensure that the shield is well-grounded.

9.5 Communication Interference

9.5.1 RS485 and CAN Communication Interference

Follow the following table for troubleshooting.

Step	Action
1	Add a 120 Ω termination resistor at each end of the bus.
2	Use a multi-core shielded twisted pair cable instead, and ground the shield at both ends.
3	Separate the communication cable from the power cable by a distance of at least 30 cm.
4	For multi-node communication, adopt the daisy chain topology for routing.
5	For multi-node communication, add an equipotential bonding grounding wire between nodes.
6	Add a ferrite clamp at each end of the communication cable, or wind the communication cable on a magnetic ring for one to two turns.
7	Wind the output U/V/W cables of the AC drive on a magnetic ring for two to four turns.
8	Use a shielded power cable and ensure that the shield is well-grounded.

9.5.2 EtherCAT and PROFINET Communication Interference

Follow the following table for troubleshooting.

Step	Action
1	Check that the communication network cables meet the specification requirements for Cat 5e shielded cables.
2	Check that the communication port is not loose or in poor contact.
3	Separate the communication cable from the power cable by a distance of at least 30 cm.
4	For multi-node communication, add an equipotential bonding grounding wire between nodes.

Step	Action
5	Check that any cable between two nodes is within 100 m in length.
6	Add a ferrite clamp at each end of the communication cable and wind the communication cable for one to two turns.
7	Wind the output U/V/W cables of the AC drive on a magnetic ring for two to four turns.
8	Use a shielded power cable and ensure that the shield is well-grounded.

9.6 Encoder Feedback Signal Errors

Follow the following table for troubleshooting.

Step	Action
1	Route the encoder cable and power cable in different cable ducts.
2	When the AC drive is far away from the motor (the motor cable is as long as 10 m), disconnect the grounding (PE) terminal from the encoder shield on the AC drive side.
3	Add a magnetic ring or ferrite clamp for the encoder signal cable close to the AC drive.
4	Wind the output U/V/W cables of the AC drive on a magnetic ring for two to four turns.
5	Use a shielded power cable and ensure that the shield is well-grounded.



19011582A05

The information in this user guide is subject to change without notice.
Copyright © Shenzhen Inovance Technology Co., Ltd.

Shenzhen Inovance Technology Co., Ltd.
www.inovance.com

Add.: Building E, Hongwei Industry Park, Liuxian Road, Baocheng No. 70 Zone, Bao'an District, Shenzhen

Tel: +86-755-2979 9595 **Fax:** +86-755-2961 9897

Suzhou Inovance Technology Co., Ltd.
www.inovance.com

Add.: No. 16 Youxiang Road, Yuexi Town, Wuzhong District, Suzhou 215104, P.R. China

Tel: +86-512-6637 6666 **Fax:** +86-512-6285 6720